Counterbalanced Forklift 5,000 | 7,000 lb. Capacity

KBG25/35

Series 6010 LPG Forklift Truck



Technical Data

November 2018

	POS	ITEM DESCRIPTION	UNIT	KBG25	KBG35
Specification	1.1	Manufacturer	-	KION Baoli	KION Baoli
	1.2	Manufacturer's model designation	-	D+ series	D+ series
	1.2.1	Manufacturer's type designation	-	KBG25	KBG35
	1.3	Power type	-	LPG	LPG
	1.4	Operator type	-	Rider seated	Rider seated
	1.5	Load capacity	Q kg(lb)	2270 (5000)	3177 (7000)
	1.6	Load center	C mm(in)	600 (24)	600 (24)
	1.8	Axle center to fork face	X mm(in)	484 (19)	484 (19)
	1.9	Wheel base	Y mm(in)	1700 (67)	1700 (67)
Weight	2.1	Service weight	kg(lb)	4320 (9524)	5080 (11199)
	2.2	Axle weight with rated load front/rear	kg(lb)	5100/980 (11243.5/2160.5)	7500/940 (16534/2072.5)
	2.3	Axle weight without load front/rear	kg(lb)	2060/2240 (4541.5/4938.3)	1960/3120 (4321.1/6876.8)
Wheels and Tires	3.1	Tires (SE-Super elastic PN-Pneumatic)	-	SE	SE
	3.2	Tire size front	-	28x9-15-14	28x9-15-14
	3.3	Tire size rear	-	6.5-10-10	6.5-10-10
	3.5	Wheels, number front/rear (x = driven)	-	2x (4x) / 2	2x (4x) / 2
	3.6	Track width, front	b10 mm(in)	1000 (39)	1060 (42)
	3.7	Track width, rear	b11 mm(in)	970 (38)	970 (38)
	4.1	Mast/fork carriage tilt, forward/backward	\square/\square °	6°/6°	6°/6°
Dimensions and Overall Sizes	4.2	Height of mast, lowered	h1 mm(in)	2280 (90)	2280 (90)
	4.3	Free lift	h2 mm(in)	1260 (50)	1052 (41)
	4.4	Maximum fork height (MFH)	h3 mm(in)	4800 (189)	4800 (189)
	4.5	Height of mast, extended	h4 mm(in)	5840 (230)	6073 (239)
	4.7	Height of overhead guard (cabin)	h6 mm(in)	2108 (83)	2108 (83)
	4.8	Height of seat/stand on platform	h7 mm(in)	1085 (43)	1085 (43)
	4.12	Towing coupling height	h10 mm(in)	300 (12)	300 (12)
	4.19	Overall length including forks	L1 mm(in)	3955 (156)	4105 (162)
	4.20	Length to fork face	L2 mm(in)	2665 (105)	2815 (111)
	4.21	Overall width	b1 mm(in)	1225 (48)	1295 (51)
	4.22	Fork dimensions	s/e/Lmm(in)	45/122/1220 (1.5/4.75/48)	50/125/1220 (2/5/48)
	4.23	Fork carriage to ISO 2328, class/type A, B	-	2A	3A
	4.24	Width of fork carriage	b3 mm(in)	1040 (41)	1100 (43)
	4.31	Ground clearance, below mast	m1 mm(in)	135 (5)	135 (5)
	4.32	Ground clearance, center of wheelbase	m2 mm(in)	140 (6)	140 (6)
	4.33	Aisle width with pallet 1000 x 1200 across forks	Ast mm(in)	4124 (162)	4224 (166)
	4.34	Aisle width with pallet 800 x 1200 across forks	Ast mm(in)	4324 (170)	4424 (174)
	4.35	Turning radius	Wa mm(in)	2440 (96)	2540 (100)
	4.36	Minimum pivoting point distance	b13 mm(in)	810 (32)	810 (32)
Performance	5.1	Travel speed, with/without load	km/h(mph)	17/18 (10.6/11.2)	17/18 (10.6/11.2)
	5.2	Lifting speed, with/without load	mm/s(fpm)	514/657 (101.2/129.3)	522/667 (102.9/131.3)
	5.3	Lowering speed, with/without load	mm/s(fpm)	426/387 (83.1/76.2)	470/437 (92.6/86)
	5.5	Drawbar pull, with/without load	kN(lpf)	17000/13000 (3821/2922)	17000/10000 (3821/2248)
	5.7	Gradeability, with/without load	%	20	20
	5.10	Service brake	-	mech/hydr.	mech/hydr.
Engine	7.1	Engine manufacturer	-	IMPCO technologies, Inc.	IMPCO technologies, Inc.
	7.1.1	Engine type	-	GCT K25	GCT K25
	7.2	Engine power in compliance with ISO 1585	kW	44	44
	7.3	Rated speed	1/min(RPM)	2700	2700
Others	7.4	No. of cylinders	-	4	4
	8.1	Transmission type	-	Electron Hydraulic	Electron Hydraulic
	10.1	Working pressure for attachments	bar(psi)	2530 (175)	2530 (175)
	10.4	Volume fuel tank	l(gal)	50 (13.21)	50 (13.21)

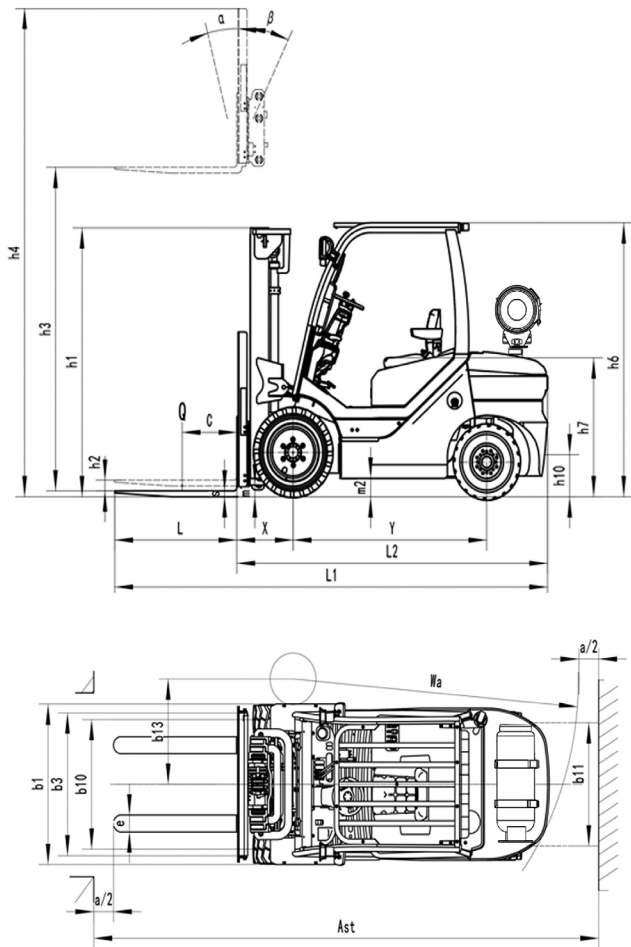

Performance

The IMPCO K25 engine with an IMPCO fuel system provides outstanding quality and performance and exceeds the standard for economy segment forklift trucks. The timing chain driven camshaft ensures maximum durability while the innovative deceleration fuel shutoff maximizes energy efficiency.

Quality & Support

Optimized standard specifications allow Baoli to offer higher quality trucks and parts than the competition. Baoli forklifts come with the KION Standard Warranty and 12 months return on initial parts orders without penalty; the warranty excludes maintenance parts.

Service Network

Fully integrated into the KION North America supply chain and service system, Baoli provides shared resources from brother brands and offers a well-developed sales and service network. With Baoli spare parts in stock at KION North America warehouse, spare parts delivery is possible within 24 hours throughout the U.S. on special demand.

Standard Equipment

- Solid pneumatic drive and steer tires
- Triplex mast
- 6° forward, 6° backwards tilt
- 40.9" wide 4-roller, Class II carriage
- Wide Class II hang-on sidershifter
- Hook type Class II forks
- 40.9" wide by 37.8" high load backrest
- Overhead guard 83" high
- Left and right external rear view mirrors
- Entry grip OHG left
- Tilting adjustable steering column
- Comfort suspension seat
- 3 individual hydraulic control levers
- 3rd function valve
- 3rd function reeving triple mast
- LED twin spotlights forward - OHG mounted
- Back-up alarm and strobe light
- Gas bottle bracket
- Operating instructions/Finish and Marking English
- Standard KION Warranty

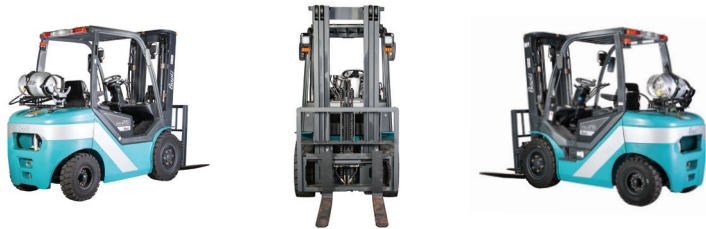



Engine

- IMPCO K25 2.5L engine
- 500-hour oil change interval
- Proven durable technology
- Quick response to changing conditions



Truck Design

- KION standard torque converter
- Low center of gravity
- Standard KION structure painting available

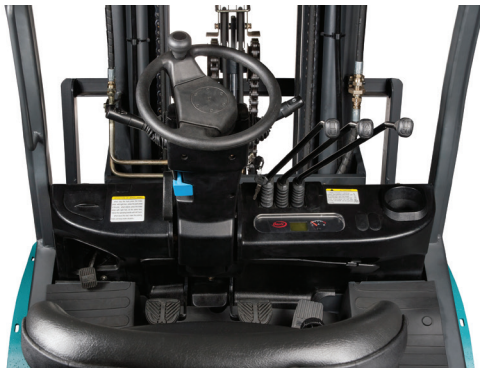

Operator Compartment

- Fully suspended cab
- Wide rear view design
- All-in-one control box for onboard diagnostics



Maintenance

- Removable suspension
- Easy access for repairs
- Engine hood opens to a 90° angle
- Easy accessibility of transmission oil gauge and brake oil gauge

KION North America Corporation
2450 West 5th North Street, Summerville, SC 29483
Phone: 843 875 8000 Truck Sales Fax: 843 875 8471
E-mail: trucksales.na@kiongroup.com
www.kion-na.com

Standard truck meets all applicable mandatory requirements of ANSI/ITSDF B56.1 standards for powered industrial trucks. NOTE: Performance data may vary due to motor and system efficiency tolerances. The performance depicted represents nominal values obtained under typical operating conditions. Metric dimensions are in millimeters unless otherwise specified. All metric dimensions are not direct equivalents due to rounding data. The descriptions and specifications included on this data sheet were in effect at the time of printing. KION North America Corporation reserves the right to make improvements and changes in specification or design without notice and without incurring obligation. Please check with your authorized Baoli dealer for information on possible updates or revisions.