



# J2 Joey

## Mid Level Order Pickers

Patents Pending

**TOTAL**  
**WAREHOUSE**

www.totalwarehouse.com

833-868-2500



### CAPACITIES

- J2-126 / J2-144: 2,000 lbs. @ 24" LC on forks to 126"
- J2-144: 1,500 lbs. @ 24" LC on forks above 126"
- 300 lbs. operators compartment

### BATTERY INFORMATION

Compartment: 29.1" x 11" x 30"  
Anderson 175 Gray A-22  
Minimum battery weight 700 lbs.

### PERFORMANCE

#### MAXIMUM LIFT HEIGHTS

J2-126: 132" platform, 126" forks

J2-144: 150" platform, 144" forks

#### Maximum Speeds

Travel: Variable from 0 mph to 4.5 mph at ground level, speeds automatically reduced with increased elevation to slow at max height.

LIFT: Up to 42 fpm

### WHEELS / TIRES

- (1) 9" x 3" poly drive tire
- (2) 3" x 2" poly stability casters
- (2) 6.5" x 4.7" poly load wheels

### ELECTRICAL

Dual 24-volt ZAPI ACO travel and power steering controllers.

LCD dashboard displays hour meter, battery state of charge, travel speed, drive wheel directional indicator, and fault codes.

AC drive motor provides high torque throughout the entire drive range. The brushless design of the AC motors drastically reduces maintenance costs while extending duty cycle. Travel speed remains constant relative to throttle position regardless of the load on truck.

(4) selectable travel speed settings and a global turtle travel speed setting can be used to tailor equipment performance to the experience level of the operator and use.

### MAST

Heavy duty I-beam design provides excellent stability at height. Steel mast channels and side mounted lift cylinders increase total vehicle capacity and service life.

### CHASSIS

Three point chassis design with along with 180° drive motor steering arc provides exceptional maneuverability. Powerhead mounted stability casters add additional truck stability and operator confidence at working heights.

### OPERATOR COMPARTMENT

Ergonomic fingertip control for travel, lift, and lower functions provide the operator with logical intuitive drive characteristics while traveling at elevation or lowered.

The operator compartment is designed for comfort and features a ergonomic floormat and features a foreward and backrest cushion. Retractable compartment side-rails allow for easy egress from either side of the vehicle.

### REGENERATIVE BRAKES

Regenerative braking is applied when the operator removes their hand from travel control or when plugging occurs. An electromagnetic parking brake is applied after the truck is stopped.

### STANDARD FEATURES

- 42" forks with pallet clamp
- Anchor, operator harness & tether
- Overhead guard
- Non-marking tires
- Rear flashing light
- Battery compartment rollers
- Low 9" step height compartment

### OPTIONAL EQUIPMENT

- 12 volt accessory power supply
- 24 volt Industrial battery
- 24 volt external charger
- Custom fork lengths

### OPERATOR CONTROLS



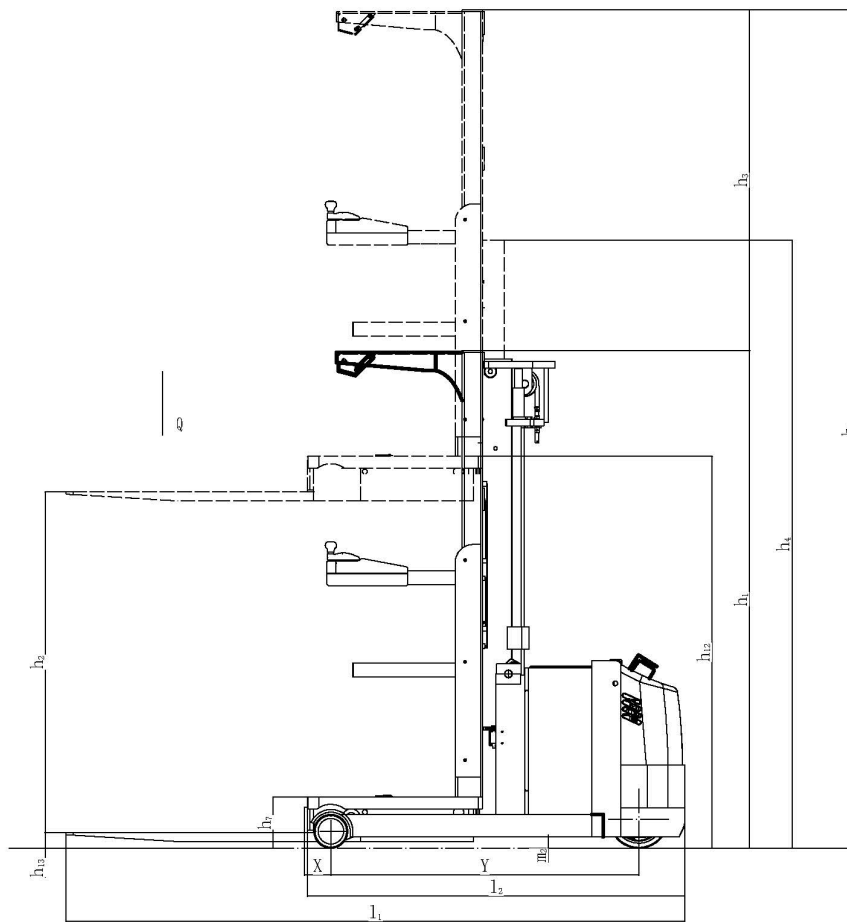

$h7 = 8.75"$  Lowered operator platform height

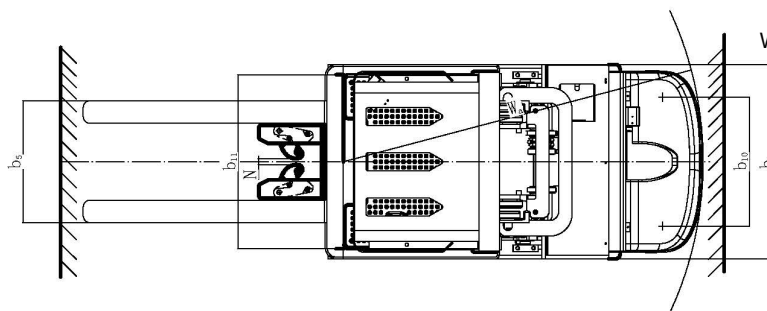

$Wa = 63"$  Turning Radius



Model #	Mast	Lift Height	Col Height	Extended Height	Overall Width	Overall Length	<sup>3</sup> Weight Chassis Only
		$h2+h3$	$h1$	$h4$	$b3 / b1$	$L1$	
J2-126	Two Stage	126	89.5	211	34.0	108.0	3500lbs.
J2-144	Two Stage	144	94.0	230	34.0	108.0	3800lbs.

All measurements in standard "inch" units, for additional specifications or performance details consult factory

<sup>3</sup> Estimated shipping weight without battery

# TOTAL WAREHOUSE

www.totalwarehouse.com

833-868-2500