



LITHIUM FORKLIFT

EASY, RAPID
PLUG-N-CHARGE
ENERGY
SYSTEM

CLEAN
LITHIUM
ELECTRIC
BATTERY

LXE-50

CAPACITY - 5,000 LBS

BATTERY/CHARGER

80v UL recognized 460AH Li-Ion battery, when paired with our 480 3-phase charger, is capable of delivering a full charge in less than 3 hours. Saves money by eliminating the need for regular maintenance or facility equipment such as eye wash stations.

PERFORMANCE

TRAVEL	LIFT	LOWERING
9.3 mph empty	Up to 98.4 fpm empty	Up to 88.6 fpm empty
9.0 mph loaded	Up to 74.8 fpm loaded	Up to 98.4 fpm loaded

TIRES

FRONT	REAR
21 x 7-15 smooth cushion	16 x 6-10.5 smooth cushion

OPERATOR COMPARTMENT

Operator compartment is exceptionally spacious due to purpose-built design for an integrated lithium battery. Ergonomic controls are provided for lift, lower, tilt and sideshift, which are within easy reach of the operator. Visibility is excellent through the wide view mast. Power steering with assist knob, adjustable steering column & adjustable suspension seat ensures comfortable working position and reduced fatigue during operation. Large mirror and overhead guard mounted hand rail aids operator when driving the in the reverse direction of travel. LCD programmable display communicates travel speed, battery discharge information, hour meter, and fault codes.

HYDRAULICS

Three function for lift, tilt and sideshift and standard. Optional 4th valve, with control and hosing is available to support two function attachments.

ELECTRICAL

80v AC controller technology delivers high efficiency and performance while significantly reducing maintenance cost and extending vehicle service life.

Battery management system monitors lithium battery performance during operation and charging to help extend battery service life far longer than traditional lead acid industrial batteries.

DRIVE UNIT AND BRAKES

Dual AC driver motors deliver smooth torque and speed curves matched to vehicle needs in real time for peak efficiency and performance. Regenerative neutral braking extends duty-cycle. Vehicle's wet disc hydraulic brakes and foot actuated parking brake ensure effective stopping power during operation and when on rated grades.

FRAME AND MAST

Heavy duty steel chassis features long wheel-base, wide tires and low center of gravity for stable operation. Wide view mast with a Class II carriage includes integral side-shift and load back rest (LBR). High seating position gives the operator an excellent view for efficient load handling at ground level and elevation. riple stage wide view masts deliver maximum lift heights of up to 197".

SERVICEABILITY

On-board programmable LCD display allows for troubleshooting and system adjustments without need of tools. Units come pre-wired for optional telematics system that includes cloud based maintenance monitoring, GPS tracking and related data services.

STANDARD FEATURES

- LED Headlights and brake lights
- Turn signals & back up alarm
- Solid cushion tires
- Integral sideshift
- Wet disc brakes
- USB accessory charging port
- Reverse travel grab handle with horn
- Adjustable suspension seat
- 42" Forks

OPTIONAL EQUIPMENT

- 48" Forks
- 48" or 60" LBR
- Hang on sideshift in lieu of integral
- Telematics package
- Sideshifting fork positioner
- 4 way hydraulics w/ no attachments
- 4 way hydraulics w/ hang on SS
- Blue light
- 480 vac, 240 vac or 120 vac charger

DIMENSIONS

LITHIUM FORKLIFT

EFLC25



UL RECOGNIZED LITHIUM SOLUTION: FAST CHARGE, CLEAN POWER, LOW COST

- 6-6.5 hour run time with up to 20% recharge in less than 30 minutes.
- No fumes, watering, or eye wash stations required
- Lowest operating cost of any general purpose forklift

EFLC25 Rated Capacity

5000 lbs. up to 130" at 24" LC
 4000 lbs. up to 189"/197" at 24" LC
Gradeability: 16% Loaded 15% and Unloaded

5 YEAR
10,000 HOUR

LITHIUM BATTERY

WARRANTY

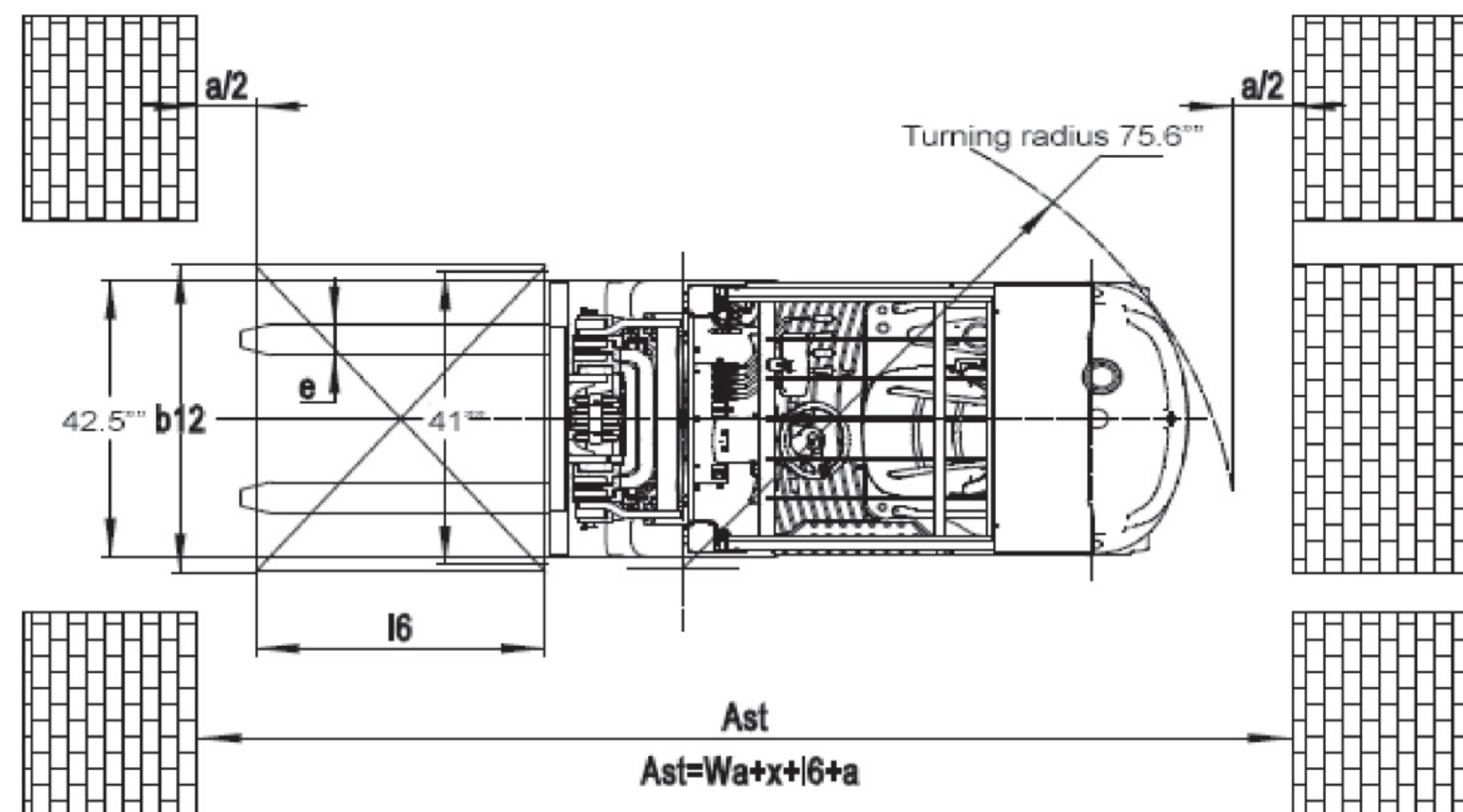
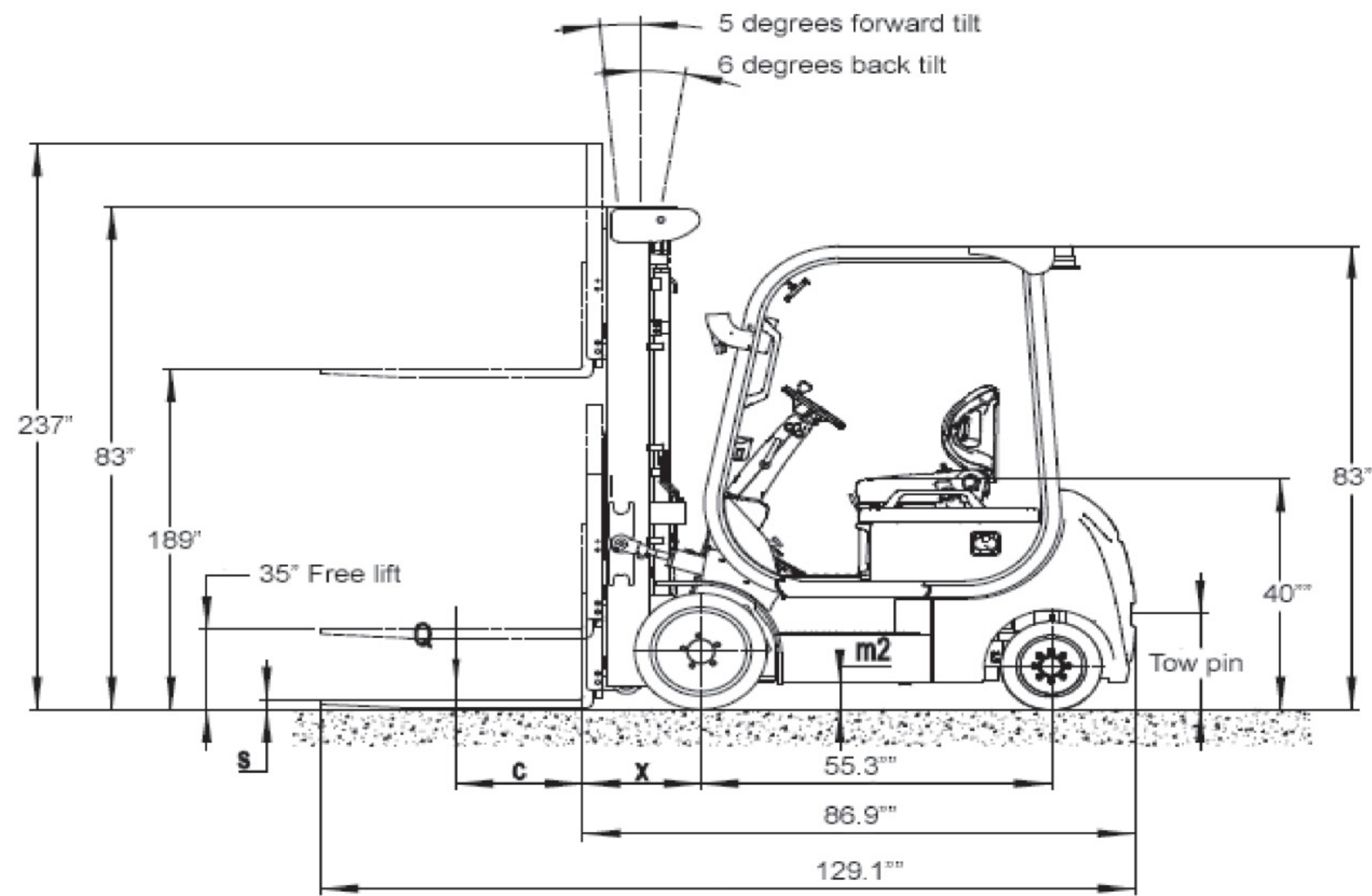

MODEL#	MAST	LIFT HEIGHT	COLLAPSED HEIGHT	FREE LIFT WITH BACKREST	EXTENDED HEIGHT WITH BACKREST	WEIGHT
		A	B	C	D	
5,000 lbs. up to 130" at 24" load center						
EFLC25-189	Three Stage	189	83.3	35	237	9,416 lbs.
EFLC25-197	Three Stage	197	90.7	40.4	245	9,490 lbs.