

Electric Pallet Truck Daily Checklist

DATE	<input type="text"/>	I INSPECTED BY	<input type="text"/>
MAKE	<input type="text"/>	MODEL	<input type="text"/>
		SN#	<input type="text"/>
HOUR	<input type="text"/>	VOLTAGE	<input type="text"/>

MARK BOX If NO PROBLEMS Visible. KEEP UNMARKED and WRITE IN Comment if PROBLEMS ARE PRESENT.

VISUAL INSPECTION

Comments

1. Main ON/OFF Switch_____
2. Hour Meter_____
3. Key Switch_____
4. Spec Plate Location_____
5. Directional/Speed Control_____
6. Emergency Reverse Button_____
7. Lift/Lower Button/Lever_____
8. Horn Button_____
9. Battery_____
 - Vent Caps_____
 - Connector Covers_____
 - Cables_____
 - Water Level_____
10. Forks_____
11. Load Wheels_____
12. Caster Wheel_____
13. Drive Wheel_____

OPERATIONAL INSPECTION

Comments

- A. Listen for Unusual Noise_____
- B. Lifting Control_____
- C. Forward Driving_____
 - Accelerator_____
 - Steering_____
 - Braking_____
- D. Reverse Driving_____
 - Accelerators_____
 - Steering_____
 - Braking_____
 - Backup Alarm_____
- E. Horn_____
- F. Gauges_____
- G. Oil Spots on Floor_____

SIGNATURE: _____

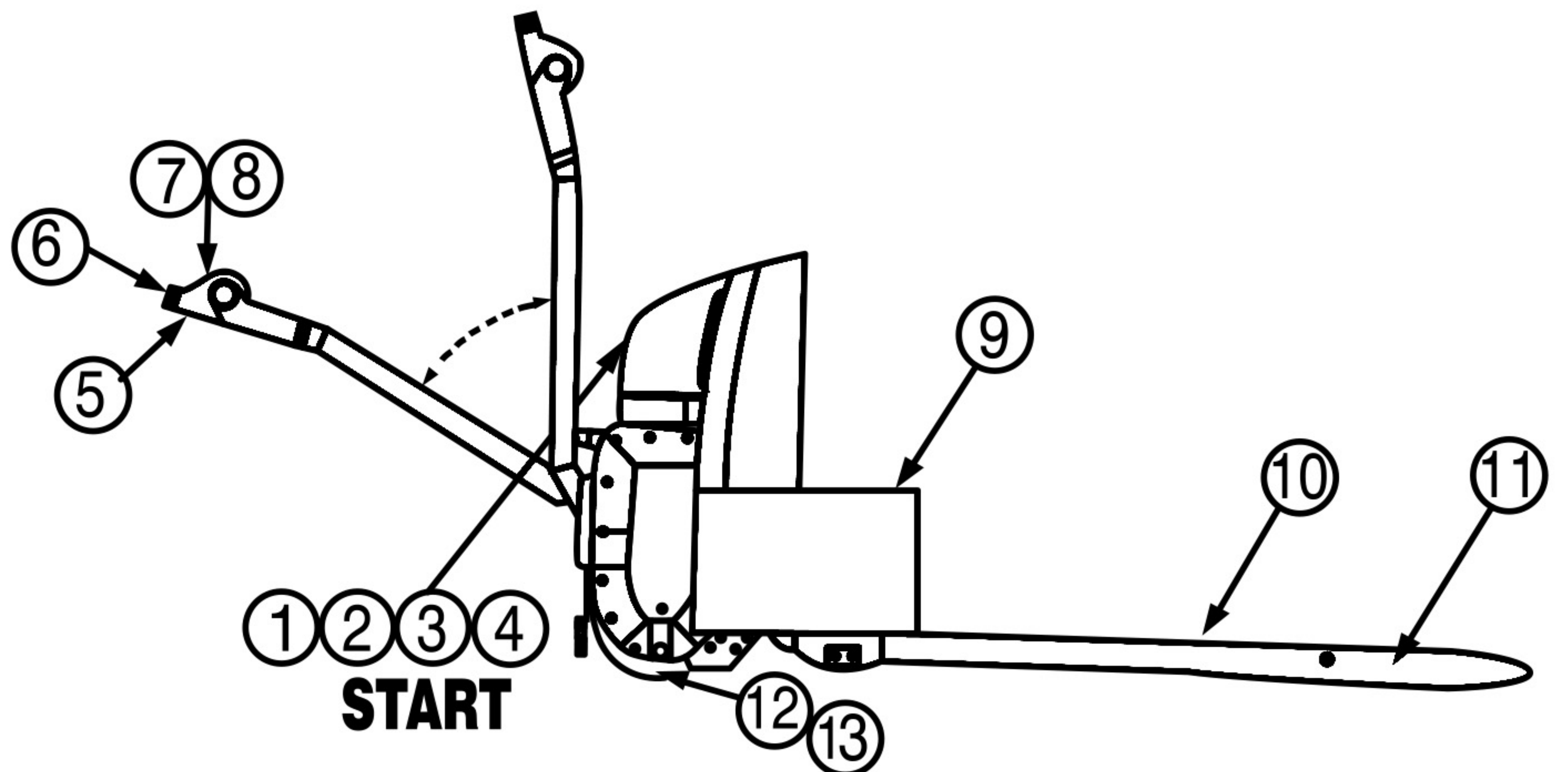

All comments made in reference to any problems should be made on the back of this page in detail and handed to the supervisor immediately.

CAUTION: This is not a complete list of all items which may require attention. Operators are responsible for ensuring that the lift truck is in proper working condition in accordance with the manufacturer's specifications.

DO NOT operate lift truck if a problem is detected. Report all problems to the service department immediately.