



LPG COUNTERBALANCED TRUCKS

CAPACITY: 5,000 – 6,500 lbs.

HT25T - HT32T

SERIES 1219

Safety

This line of trucks is designed for the demanding conditions of the Class 5 market. A low-mounted propane tank and dashboard, combined with a clearview mast (peripheral view) increase all-around visibility. This, together with low noise level and simple operation allow operators to stay alert and maintain unparalleled awareness of their surroundings.

Performance

With its impressive performance the truck still maintains low fuel consumption and low exhaust emissions. Advanced engine technology combined with the durable drive line enables the operator to use the trucks capability to maximize productivity. The ergonomic layout of all hydraulic functions allow for a high level of precision fingertip control and working performance.

Comfort

Climb on board relaxed, finish the shift relaxed. This truck is designed to the most advanced ergonomic standards. A spacious cab interior with accessibility from both sides of the truck, deck-mounted hydraulic controls, suspension seat, and functional positioning of easy-actuation controls make for a low-stress working environment.

Reliability/Durability

This machine withstands the most brutal conditions in severe applications thanks to our time-tested engineering, design and manufacturing expertise. Its solid components are designed to operate in adverse conditions and can handle intense utilization with minimum care.

Productivity

The use of high-quality parts and assemblies allow extended maintenance intervals. At 500 hours, this is among the best in the industry. Confidence in the quality of the machine also allows us to offer an unmatched, standard 2-year or 4000-hour warranty.

TECHNICAL DATA

June 2017 / Series 1219

		LINDE		LINDE		LINDE		LINDE	
		HT25T	HT27T	HT30T	HT32T				
Characteristics	1.1	Manufacturer		LINDE		LINDE		LINDE	
	1.2	Model designation		HT25T		HT27T		HT30T	
	1.3	Power unit		LP Gas		LP Gas		LP Gas	
	1.4	Operation		Seated		Seated		Seated	
	1.5	Load capacity	Q	5000 lbs 2268 kg	5500 lbs 2500 kg	6000 lbs 2727 kg	6500 lbs 2955 kg	6500 lbs 2955 kg	2955 kg
	1.6	Load center	c	24 in 600 mm	24 in 600 mm	24 in 600 mm	24 in 600 mm	24 in 600 mm	600 mm
	1.8	Axle center to fork face	x	20 in 501 mm	20 in 501 mm	20 in 504 mm	20 in 504 mm	20 in 504 mm	504 mm
	1.9	Wheelbase	y	67 in 1700 mm	67 in 1700 mm	67 in 1700 mm	67 in 1700 mm	67 in 1700 mm	1700 mm
	Weights	2.1	Service weight		9259 lbs 4200 kg		9722 lbs 4410 kg		10295 lbs 4670 kg
2.2.1		Axle load with load, front		12176 lbs 5523 kg		12808 lbs 5810 kg		13800 lbs 6260 kg	
2.2.2		Axle load with load, rear		2094 lbs 950 kg		2425 lbs 1100 kg		2507 lbs 1137 kg	
2.3.1		Axle load without load, front		3814 lbs 1730 kg		3681 lbs 1670 kg		3769 lbs 1710 kg	
2.3.2		Axle load without load, rear		5445 lbs 2470 kg		6040 lbs 2740 kg		6525 lbs 2960 kg	
Wheels/Tires	3.1	Tire: SE=(super elastic), P=(pneumatic)		P		P		P	
	3.2	Tire size, front		27x10-12		27x10-12		27x10-12	
	3.3	Tire size, rear		6.50-10/14		6.50-10/14		6.50-10/14	
	3.5	Wheels, number front/rear(X=drive)		2X/2		2X/2		2X/2	
	3.6.1	Track width, front	b10	42 in 1058 mm	42 in 1058 mm	42 in 1058 mm	42 in 1058 mm	42 in 1058 mm	1058 mm
	3.6.2	Track width, rear	b11	37 in 942 mm	37 in 942 mm	37 in 942 mm	37 in 942 mm	37 in 942 mm	942 mm
Dimensions	4.1	Mast tilt, forward/backward		6°/8°		6°/8°		6°/8°	
	4.2	Height of mast, lowered	h1	see chart & price pages		see chart & price pages		see chart & price pages	
	4.3	Free lift	h5	see chart & price pages		see chart & price pages		see chart & price pages	
	4.4	Lift	h3	see chart & price pages		see chart & price pages		see chart & price pages	
	4.5	Height of mast, extended	h4	see chart & price pages		see chart & price pages		see chart & price pages	
	4.7	Height of overhead guard (cabin)	h6	85 in 2170 mm	85 in 2170 mm	85 in 2170 mm	85 in 2170 mm	85 in 2170 mm	2170 mm
	4.8	Height of drive seat	h7	44 in 1120 mm	44 in 1120 mm	44 in 1120 mm	43 in 1120 mm	43 in 1120 mm	1120 mm
	4.12	Tow coupling height	h10	24 in 610 mm	24 in 610 mm	24 in 610 mm	24 in 610 mm	24 in 610 mm	610 mm
	4.20	Length to fork face	l2	108 in 2745 mm	109 in 2760 mm	110 in 2800 mm	112 in 2850 mm	112 in 2850 mm	2850 mm
	4.21	Overall width	b1/b2	51 in 1306 mm	51 in 1306 mm	51 in 1306 mm	51 in 1306 mm	51 in 1306 mm	1306 mm
	4.24	Width of fork carriage	b3	45 in 1150 mm	45 in 1150 mm	45 in 1150 mm	45 in 1150 mm	45 in 1150 mm	1150 mm
	4.31	Ground clearance with load, mast	m1	5.3 in 135 mm	5.3 in 135 mm	5.3 in 135 mm	5.3 in 135 mm	5.3 in 135 mm	135 mm
	4.32	Ground clearance with load, center of wheelbase	m2	7 in 170 mm	7 in 170 mm	7 in 170 mm	7 in 170 mm	7 in 170 mm	170 mm
	4.34.1	Aisle width, 48" (1220mm) load & 8" (200mm) clearance	Ast	167.8 in 4263 mm	167.8 in 4263 mm	167.8 in 4263 mm	167.8 in 4263 mm	167.8 in 4263 mm	4263 mm
4.34.2	Aisle width, add load & operational clearance	Ast	112.1 in 2848 mm	112.1 in 2848 mm	112.1 in 2848 mm	112.1 in 2848 mm	112.1 in 2848 mm	2848 mm	
4.35	Turning radius	Wa	95 in 2425 mm	97 in 2458 mm	98 in 2495 mm	99 in 2527 mm	99 in 2527 mm	2527 mm	
4.36	Minimum pivoting point distance	b13	24 in 597 mm	24 in 597 mm	24 in 597 mm	24 in 597 mm	24 in 597 mm	597 mm	
Performance	5.1.1	Travel speed, with load		11.8 mph 19 kmh		11.8 mph 19 kmh		11.8 mph 19 kmh	
	5.1.2	Travel speed, without load		11.8 mph 19 kmh		11.8 mph 19 kmh		11.8 mph 19 kmh	
	5.2.1	Lifting speed, with load		108 fpm 0.55 m/s		108 fpm 0.55 m/s		108 fpm 0.55 m/s	
	5.2.2	Lifting speed, without load		118 fpm 0.60 m/s		118 fpm 0.60 m/s		108 fpm 0.55 m/s	
	5.3.1	Lowering speed, with load		98 fpm 0.50 m/s		98 fpm 0.50 m/s		98 fpm 0.50 m/s	
	5.3.2	Lowering speed, without load		78 fpm 0.40 m/s		78 fpm 0.40 m/s		78 fpm 0.40 m/s	
	5.6.1	Tractive force, with load		3372 lbf 15000 N		2945 lbf 13100 N		2923 lbf 13000 N	
	5.6.2	Tractive force, without load		2698 lbf 12000 N		2608 lbf 11600 N		2473 lbf 11000 N	
	5.8.1	Climbing ability, with load		24 %		20 %		18 %	
	5.8.2	Climbing ability, without load		30 %		28 %		22 %	
5.10	Service brake		Mechanical/Hydraulic		Mechanical/Hydraulic		Mechanical/Hydraulic		
Drive	6.4	Manufacturer of engine/type		IMPCO 2.5L iVCT		IMPCO 2.5L iVCT		IMPCO 2.5L iVCT	
	7.1	Engine performance		63 hp 47 kw		63 hp 47 kw		63 hp 47 kw	
	7.2	Rated speed		2800 rpm		2800 rpm		2800 rpm	
	7.3	Number of cylinders / displacement		4 / 152.5 in³ 4 / 2500 cc		4 / 152.5 in³ 4 / 2500 cc		4 / 152.5 in³ 4 / 2500 cc	
Other	8.1	Type of drive control		Torque Converter		Torque Converter		Torque Converter	
	8.2	Working pressure for attachments		2611 psi 180 bar		2611 psi 180 bar		2611 psi 180 bar	

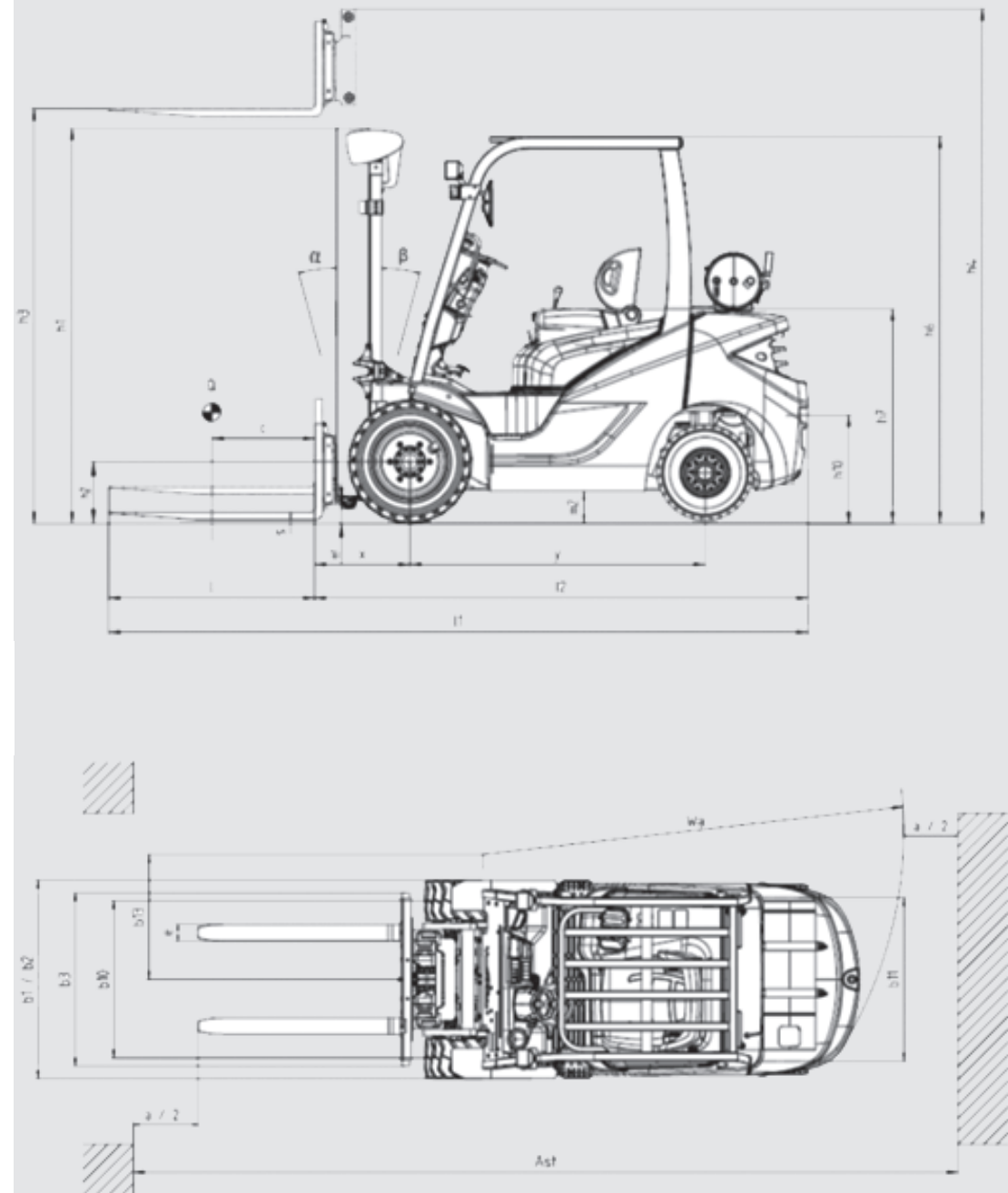

FEATURES

Linde Torque Converter Truck

- > Robust
- > Responsive
- > Low maintenance



Rugged Drive Line

- > Massive differential
- > High-torque transmission
- > Wet disc brakes

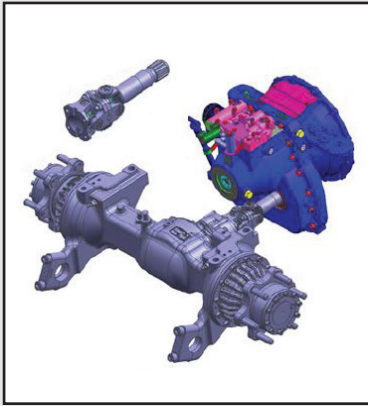

Linde Clearview Mast

- > Best peripheral view
- > Least obstructive hose routing
- > Bulkhead hose connection



Engine

- > 500-hour maintenance interval
- > Fuel injected
- > 2.5 liter, high-torque engine



Truck Control

- > Two pedal system, inching and brake
- > Foot-operated parking brake
- > Easy-read display
- > Responsive accelerator pedal

Linde Hydraulic System

- > Deck-mounted control handles
- > Short linkage
- > High oil volume

Linde Operator Compartment

- > Ample space
- > On/Off both sides
- > Excellent rearward visibility
- > Standard full suspension seat

For more information on Linde material handling equipment, please contact:

TOTAL
WAREHOUSE
TotalWarehouse.com
833-868-2500