



ELECTRIC COUNTERBALANCED TRUCK E25C - E32CL

TOTAL
WAREHOUSE

5,000 - 6,500 lbs. Capacity

Series 1347

- Rugged durability paired with highly reliable internal components makes the Series 1347 a dependable workhorse for the widest variety of applications
- The dual AC-motor compact drive axle with Linde Load Control provides exceptional stability and precise load handling in an energy-efficient package for productive multi-shift operations
- The interactive display unit includes on-board diagnostics and guided calibration to simplify troubleshooting and support scheduled maintenance
- The full-suspension seat can be paired with sturdy mechanical levers or precise electronic hydraulic control levers for optimum handling of heavy loads at all heights
- High visibility is achieved through the Linde clear view mast by using narrow rail profiles and clever hose routing. The design encourages productivity and speed, while remaining fully focused on safety

STANDARD & OPTIONAL EQUIPMENT

STANDARD

- 36-volt and 48-volt configuration
- Dual-pedal travel control
- Cushion tires
- Lift-out battery exchange
- Standard 88" overhead guard
- Three-function hydraulic valve
- Three-function control levers
- Linde Load Control
- Standard tilt (6°F / 5°B)
- Full-suspension vinyl seat
- Two front work lights
- Key switch start
- SB350 battery connector
- Emergency power interrupt button
- UL classification, Type E
- High-visibility orange seat belt
- Maintenance-free wet-disc brakes
- 100% AC traction and lift motors
- Multi-function display with on-board diagnostics
- Tow pin and tie-down cutouts
- Electronic forward horn
- Hydrostatic power steering system
- Adjustable steering column
- Heavy-duty casting steer axle
- Linde Curve Assist speed-control
- Steel entry handle
- Spring-assisted battery cover
- 1000-hour maintenance intervals
- 3-year / 6000-hour (standard warranty)

OPTIONAL

- Single-pedal travel control
- Non-marking tires
- Side battery removal with slides/rollers
- Simplex, duplex, triplex, and quad masts
- 38.6" Class II/III fork carriage
- Integrated / hang-on sideshifter
- Low-profile and drive-in rack overhead guard
- Overhead guard top cover, clear
- Four-function hydraulic valve
- Electronic, fingertip control levers
- Bottler's tilt (10°F / 5°B)
- Auxiliary function hydraulic hose reeving
- Quick-disconnect hydraulic fittings
- High-comfort suspension seat with tiltable armrest
- Tilt angle memory
- Load backrest extension 48"
- LED work lights
- Linde BlueSpot™
- LED rear combination light bars
- Flashing amber strobe light
- Back-up alarm
- Rear handle with horn button
- Fire extinguisher (2.5 lb dry chemical)
- Panoramic rear-view mirror
- Flat rear-view mirror
- Paperwork clipboard
- Seatbelt interlock switch
- Keyless start switch
- Operator fan
- Cold-storage protection
- UL classification, Type EE

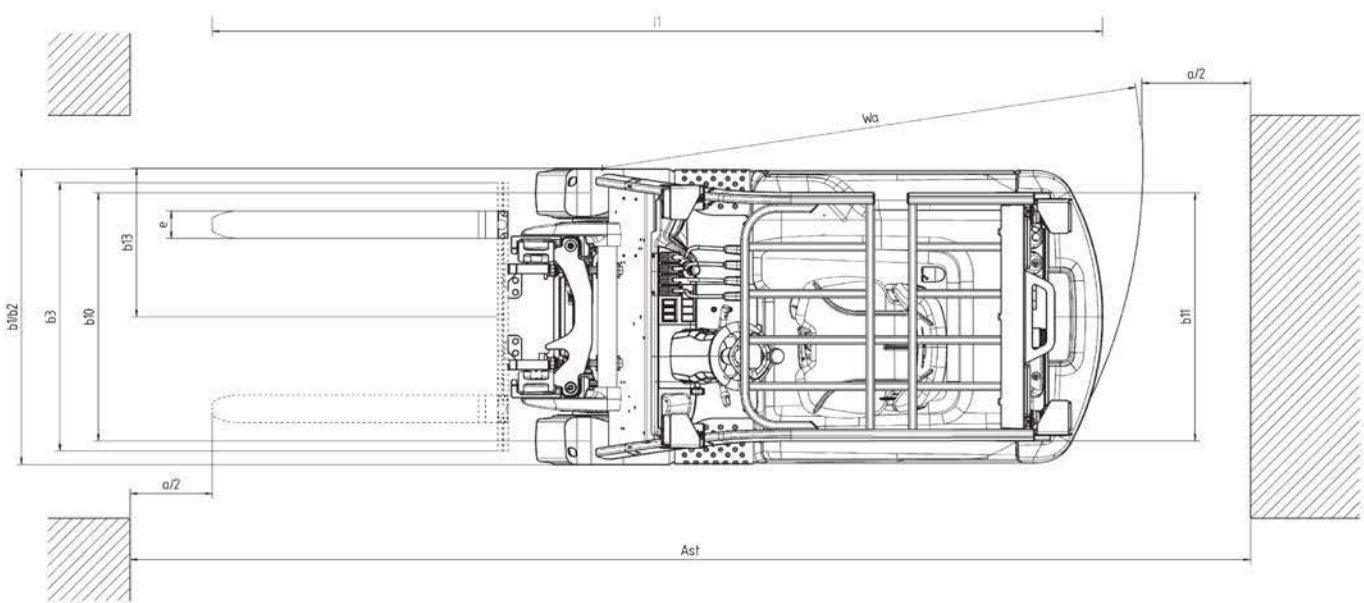
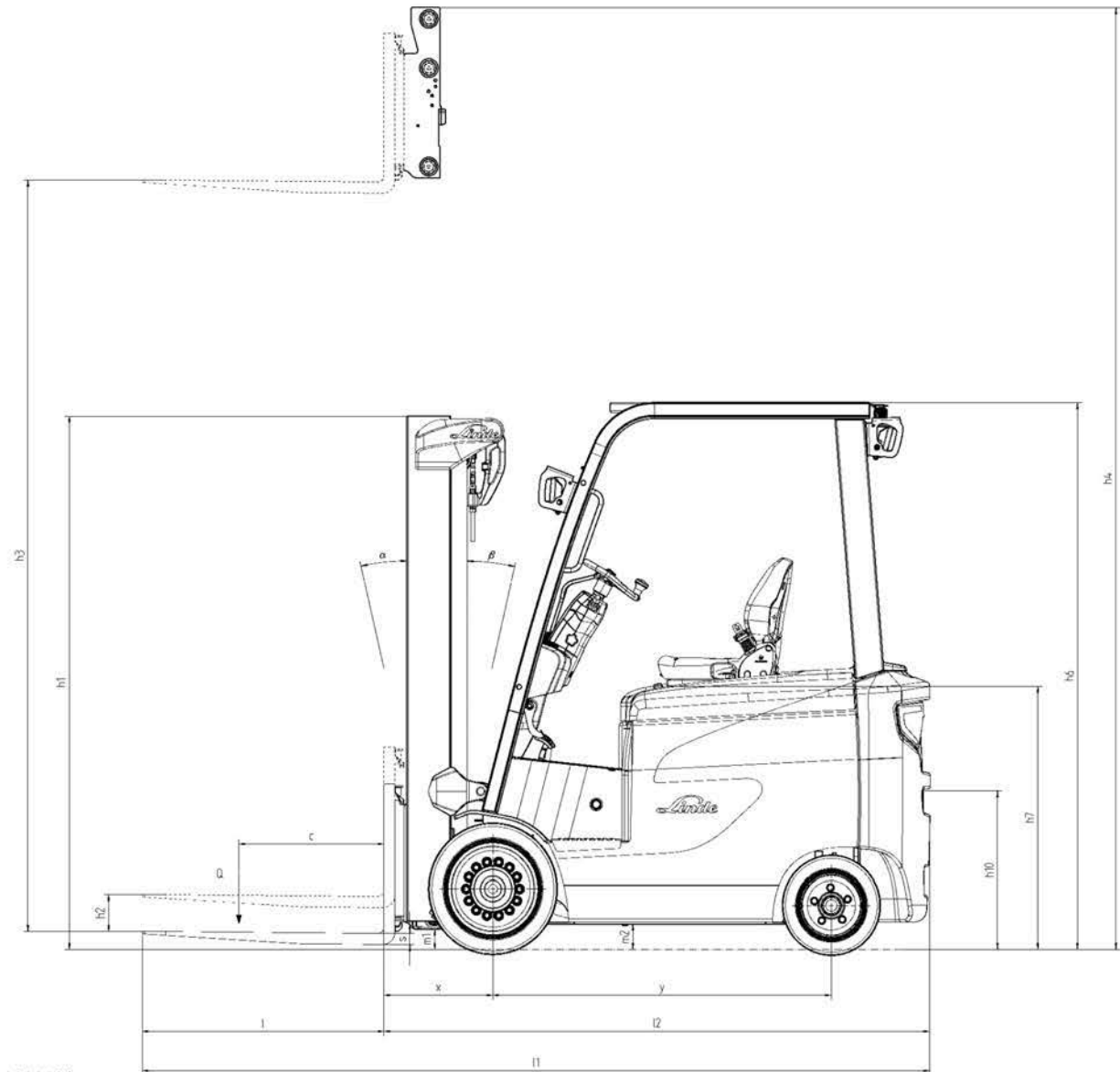

TECHNICAL DATA

February 2020

					LINDE		LINDE		
					E25C		E25CL		
Characteristics	1.1	Manufacturer			LINDE		LINDE		
	1.2	Model designation			E25C		E25CL		
	1.3	Power unit			Electric		Electric		
	1.4	Operation			Seated		Seated		
	1.5	Rated capacity	Q	lbs	kg	5000	2273	5000	2273
	1.6	Load center Distance	c	in	mm	24	600	24	600
	1.8	Load Distance, Center of drive axle to fork	x	in	mm	17.6	447	17.6	447
	1.9	Wheelbase	y	in	mm	51.2	1300	55.1	1400
	Weights	2.1	Service weight		lbs	kg	10623	4820	10844
2.2		Axle loading, loaded front/rear		lbs	kg	13555 / 2138	6150 / 970	13823 / 2094	6270 / 950
2.3		Axle loading, unloaded front/rear		lbs	kg	4364 / 6259	1980 / 2840	4938 / 5908	2240 / 2680
Wheels/Tires	3.1	Tire type			Cushion		Cushion		
	3.2	Tire size, front			21x7x15		21x7x15		
	3.3	Tire size, rear			16x6x10.5		16x6x10.5		
	3.5	Wheels, number front/rear (x=driven)			2x / 2		2x / 2		
	3.6	Track width, front	b ₁₀	in	mm	35.0	890	35.0	890
	3.7	Track width, rear	b ₁₁	in	mm	35.8	910	35.8	910
	Dimensions	4.1	Mast tilt, forward/backward	a / b	Degrees	Degrees	6°/5°		6°/5°
4.2		Height, mast lowered	h ₁	in	mm	85.8	2179	85.8	2179
4.4		Maximum fork height	H	in	mm	185.8	4720	185.8	4720
4.5		Height mast extended	h ₄	in	mm	214.4	5446	214.4	5446
4.7		Height of overhead guard	h ₆	in	mm	88.0	2235	88.0	2235
4.8		Seat height	h ₇	in	mm	49.4	1255	49.4	1255
4.12		Coupling height	h ₁₀	in	mm	23.5	597	23.5	597
4.19		Overall Length	l ₁	in	mm	127.1	3229	129.8	3296
4.20		Length to face of forks	l ₂	in	mm	85.0	2159	87.6	2276
4.21		Overall width	b ₁ b ₂	in	mm	42.5	1080	42.5	1080
4.24		Fork-carriage width	b ₃	in	mm	38.6	980	38.6	980
4.31		Ground clearance, loaded, below mast	m ₁	in	mm	4.1	105	4.2	106
4.32		Ground clearance, center of wheelbase	m ₂	in	mm	4.4	112	4.6	118
4.34		Aisle width, add load length and clearance	A _{it}	in	mm	91.6	2327	94.4	2398
4.35		Turning radius	W _a	in	mm	74.0	1880	76.8	1951
4.36		Internal turning radius	b ₁₃	in	mm	19.3	490	19.3	490
Performance	5.1	Travel speed, with/without load, 48V		mph	km/h	10.8 / 10.5	17.5 / 17	10.8 / 10.5	17.5 / 17
	5.1	Travel speed, with/without load, 36V		mph	km/h	9.6 / 9.3	15.5 / 15	9.6 / 9.3	15.5 / 15
	5.2	Lifting speed, with/without load, 48V		fpm	m/s	93 / 100	0.47 / 0.51	93 / 100	0.47 / 0.51
	5.2	Lifting speed, with/without load, 36V		fpm	m/s	63 / 91	0.32 / 0.46	63 / 91	0.32 / 0.46
	5.3	Lowering speed, with/without load		fpm	m/s	114 / 77	0.58 / 0.39	114 / 77	0.58 / 0.39
	5.6	Max. drawbar pull, with/without load, 48V		lbf	N	3147 / 2473	14000 / 11000	3350 / 3125	14900 / 13900
	5.6	Max. drawbar pull, with/without load, 36V		lbf	N	2630 / 2608	11700 / 11600	2585 / 2608	11500 / 11600
	5.8	Max. gradeability, with/without load, 48V		%	%	19 / 22		20 / 27	
	5.8	Max. gradeability, with/without load, 36V		%	%	16 / 23		15 / 23	
	5.10	Service brake				mechanical/electric		mechanical/electric	
Drive	6.1	Drive motor rating 52.60 min				5.8 x 2		5.8 x 2	
	6.2	Lift motor rating at 53.15%				17		17	
	6.4	Battery voltage/nominal capacity	(V)/(ah)	(V)/(ah)		36 / 1020	48 / 765	36 / 1190	48 / 850
	10.1	Operating pressure for attachments		psi	bar	2900	200	2900	200
Other	10.2	Oil volume for attachments		gpm	L/min	8.5	32	8.5	32
	10.7	Sound pressure level at the drivers seat		dB(A)	dB(A)	68 dB (A)		68 dB (A)	

¹All C chassis with 2690 lbs (1220 kg) battery
All CL chassis with 3000 lbs (1361 kb) battery

LINDE		LINDE		LINDE		LINDE		LINDE	
E27C		E27CL		E30C		E30CL		E32CL	
Electric		Electric		Electric		Electric		Electric	
Seated		Seated		Seated		Seated		Seated	
5500	2495	5500	2495	6000	2727	6000	2727	6500	2955
24	600	24	600	24	600	24	600	24	600
17.6	447	17.6	447	17.7	450	17.7	450	17.7	450
51.2	1300	55.1	1400	51.2	1300	55.1	1400	55.1	1400
11130	5050	11307	5130	11461	5200	11813	5360	12431	5640
14546 / 2226	6600 / 1010	14513 / 2171	6585 / 985	15296 / 2292	6940 / 1040	15670 / 2204	7110 / 1000	16552 / 2491	7510 / 1130
4298 / 6832	1950 / 3100	4904 / 6403	2225 / 2905	4121 / 7339	1870 / 3330	4871 / 6943	2210 / 3150	4827 / 7604	2190 / 3450
Cushion		Cushion		Cushion		Cushion/Cushion		Cushion/Cushion	
21x8x15		21x8x15		21x8x15		21x8x15		21x8x15	
16x6x10.5		16x6x10.5		16x6x10.5		16x6x10.5		16x6x10.5	
2x / 2		2x / 2		2x / 2		2x / 2		2x / 2	
36.1	918	36.1	916	36.1	918	36.1	916	36.1	916
35.8	910	35.8	910	35.8	910	35.8	910	35.8	910
6°/5°		6°/5°		6°/5°		6°/5°		6°/5°	
85.8	2179	85.8	2179	85.8	2179	85.8	2179	85.8	2179
185.8	4720	185.8	4720	186.0	4725	186.0	4725	186.0	4725
214.4	5446	214.4	5446	214.4	5446	214.4	5446	214.4	5446
88.0	2235	88.0	2235	88.0	2235	88.0	2235	88.0	2235
49.4	1255	49.4	1255	49.4	1255	49.4	1255	49.4	1255
23.5	597	23.5	597	23.5	597	23.5	597	23.5	597
129.1	3280	131.1	3329	129.4	3286	131.1	3380	133.3	3386
87.0	2210	88.9	2259	87.2	2216	90.9	2310	91.2	2316
44.2	1123	44.2	1123	44.2	1123	44.2	1123	44.2	1123
38.6	980	38.6	980	38.6	980	38.6	980	38.6	980
4.1	105	4.2	106	4.1	105	4.2	106	4.2	106
4.4	112	4.6	118	4.4	112	4.6	118	4.6	118
92.8	2357	95.6	2427	94.0	2388	96.8	2459	97.9	2487
75.2	1910	78.0	1980	76.3	1938	79.1	2009	80.2	2037
19.3	490	19.3	490	19.3	490	19.3	490	19.3	490
10.8 / 10.5	17.5 / 17	10.8 / 10.5	17.5 / 17	10.8 / 10.5	17.5 / 17	10.8 / 10.5	17.5 / 17	10.8 / 10.5	17.5 / 17
9.6 / 9.3	15.5 / 15	9.6 / 9.3	15.5 / 15	9.6 / 9.3	15.5 / 15	9.6 / 9.3	15.5 / 15	9.6 / 9.3	15.5 / 15
87 / 100	0.44 / 0.51	87 / 100	0.44 / 0.51	87 / 100	0.44 / 0.51	83 / 100	0.42 / 0.51	79 / 100	0.40 / 0.51
61 / 91	0.31 / 0.46	61 / 91	0.31 / 0.46	59 / 91	0.30 / 0.46	59 / 91	0.30 / 0.46	57 / 91	0.29 / 0.46
144 / 77	0.58 / 0.39	114 / 77	0.58 / 0.39	114 / 83	0.58 / 0.42	114 / 83	0.58 / 0.42	114 / 83	0.58 / 0.42
3035 / 2698	13500 / 12000	3147 / 3035	14000 / 13500	3260 / 2698	14500 / 12000	3013 / 2923	13400 / 13000	2923 / 2473	13000 / 11000
2675 / 2653	11900 / 11800	2473 / 2698	11000 / 12000	2585 / 2473	11500 / 11000	2608 / 2630	11600 / 11700	2563 / 2540	11400 / 11300
18 / 23		18 / 26		18 / 23		16 / 24		15 / 19	
15 / 23		14 / 22		14 / 21		13 / 22		12 / 19	
mechanical/electric		mechanical/electric		mechanical/electric		mechanical/electric		mechanical/electric	
5.8 x 2		5.8 x 2		5.8 x 2		5.8 x 2		5.8 x 2	
17		17		17		17		17	
36 / 1020	48 / 765	36 / 1190	48 / 850	36 / 1020	48 / 765	36 / 1190	48 / 850	36 / 1190	48 / 850
2900	200	2900	200	2900	200	2900	200	2900	200
8.5	32	8.5	32	8.5	32	8.5	32	8.5	32
68 dB (A)		68 dB (A)		68 dB (A)		68 dB (A)		68 dB (A)	

FEATURES



Linde Series 1347 Five Features

Operator Comfort: The operator compartment has a multitude of features, including an adjustable armrest, fingertip controls, full suspension seat with three adjustment points and an adjustable steering column.

On-board diagnostics: The Linde's on-board diagnostic system points to whatever issue needs to be resolved. This makes repairs quick and efficient by minimizing the diagnostic times required to get your truck back in service.

Compact drive unit: All drive components are contained in a completely sealed drive axle with a IP54 rating. The dual AC drive motors are mounted in-line, allowing for exceptional run times and minimal wear.

Linde Energy Management System: With AC power modules mounted directly on the sealed drive axle, Linde has been able to eliminate all AC power cables. This means less power loss and more run time.

Visibility: The Linde's nested mast design, coupled with both the lift chains and hydraulic hoses routed over top of the free lift cylinder maximizes both peripheral and through-the-mast visibility. This ensures the operator can see what is in front of them at all times.





ANSI: Standard truck meets all applicable mandatory requirements of ANSI/ITSDF B56.1 standards for powered industrial trucks.
 NOTE: Performance data may vary based on floor and system efficiency tolerance. This performance depicted represents normal usage obtained under typical operating conditions. Metric dimensions are in millimeters unless otherwise specified. All metric dimensions are not direct equivalents due to rounding data. The descriptions and specifications included on this data sheet were in effect at the time of printing. © 2020 Linde Material Handling Corporation reserves the right to make improvements and changes in specifications or design without notice and without incurring obligation. Please check with your authorized Linde dealer for information on possible updates or revisions.

For more information on Linde material handling equipment, please contact:

TOTAL
WAREHOUSE
 www.totalwarehouse.com
 833-868-2500