

**TOTAL**  
WAREHOUSE  
www.totalwarehouse.com  
833-868-2500

**NISSAN**  
FORKLIFT

# BX Platinum Series

Cushion Tire / 36 & 48 Volt / 4-Wheel AC-Powered Models

**3,000 - 8,000 lb.**  
Capacities



# BX Platinum series

## Dimensions

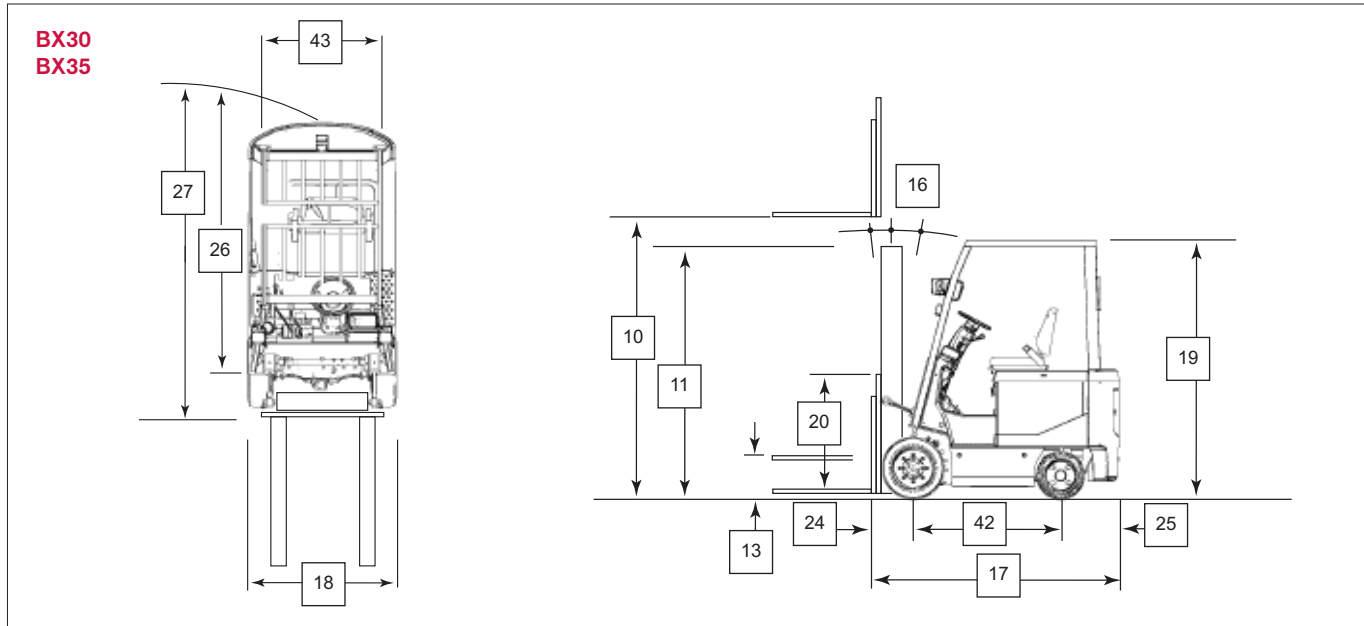

## Mast Specifications & Rated Capacities

	Mast Name	Maximum Fork Height	Overall Height Lowered	Free Lift*	Tilt angle Forward/Backward	Rated Capacity at 24" Load Center	
						BX30	BX35
<b>TWO STAGE</b> (Wide view 2W)	2W270	106	71.1	4.0	5/10	3000	3500
	2W300	118	77.0	4.0	5/10	3000	3500
	2W330	130	82.9	4.0	5/10	3000	3500
	2W350	138	88.2	4.0	5/10	3000	3500
	2W370	146	93.1	4.0	5/10	3000	3500
	2W400	157	100.6	4.0	5/10	3000	3200
	2W450	177	110.5	4.0	5/5	2850	3000
	2W500	197	120.3	4.0	5/5	2500	2100
<b>TWO STAGE</b> (Full free 2F)	2F300	118	77.0	53.0	5/10	3000	3500
	2F330	130	82.9	58.9	5/10	3000	3500
	2F350	138	88.2	64.2	5/10	3000	3500
	2F370	146	93.1	69.1	5/10	3000	3500
	2F400	157	100.6	76.6	5/10	3000	3200
<b>THREE STAGE</b> (Full free 3F)	3F385	152	71.1	48.4	5/5	3000	3500
	3F430	169	77.0	54.3	5/5	2800	3300
	3F475	187	82.9	60.2	5/5	2600	2700
	3F515	203	88.2	65.6	5/5	2400	2500
	3F550	217	93.1	70.5	5/5	2200	1800
	3F600	236	100.6	78.0	5/5	1700	1300
<b>THREE STAGE</b> (OptiView 3V)	3V360	142	71.1	49.2	5/5	2850	3350
	3V405	159	77.0	55.1	5/5	2750	3200
	3V450	177	82.9	61.0	5/5	2650	2900
	3V490	193	88.2	66.3	5/5	2500	2650
	3V525	207	93.1	71.3	5/5	2350	2300
	3V575	226	100.6	78.7	5/5	1950	1550

\* Without backrest

# 3,000 / 3,500 lb. capacities

## Main Truck Specifications

CHARACTERISTICS				Nissan		Nissan		
1	Manufacturer's Name			Nissan		Nissan		1
2	Model	Model designation		BX30		BX35		2
3		Long model code		CK1B1L15S		CK1B1L18S		3
4	Rated Load Capacity		lb (kg)	3000 (1500)		3500 (1750)		4
5	Load Center	Distance	in (mm)	24 (500)		24 (500)		5
6	Power Type	Electric	voltage	36v	48v	36v	48v	6
7	Operator Orientation			Sit		Sit		7
8	Tire Type	Front & rear		Cushion		Cushion		8
9	Wheels	Number - front/rear (x=driven)		2x / 2		2x / 2		9
10	Mast	Maximum fork height	in (mm)	130 (3300)		130 (3300)		10
11		Mast lowered (OHL)	in (mm)	82.9 (2106)		82.9 (2106)		11
12		Mast extended with LBR	in (mm)	179.3 (4555)		179.3 (4555)		12
13		Standard freelif	in (mm)	4.0 (100)		4.0 (100)		13
14	Forks	Thickness & width	in (mm)	1.5 x 4 (40x100)		1.5 x 4 (40x100)		14
15		Length (STD)	in (mm)	42.1 (1070)		42.1 (1070)		15
16	Tilt Angle	Standard mast - fwd/back	degree	5 / 10		5 / 10		16
17	Overall Dimensions	Length (to face of forks)	in (mm)	80.7 (2050)		80.9 (2055)		17
18		Width (standard tires)	in (mm)	38.2 (970)		38.2 (970)		18
19		Height - top of OHG	in (mm)	86.2 (2190)		86.2 (2190)		19
20		Height - top of standard LBR	in (mm)	48.0 (1220)		48.0 (1220)		20
21		Width - standard carriage	in (mm)	32.4 (825)		32.4 (825)		21
22	Grade Clearance	Ramp breakover angle	%	26.0		26.0		22
23		Departure angle	%	36.0		36.0		23
24	Overhang	Front	in (mm)	15.7 (400)		15.7 (400)		24
25		Rear	in (mm)	16.9 (430)		17.1 (435)		25
26	Turning Radius	Minimum outside	in (mm)	70.9 (1800)		70.9 (1800)		26
27	Min Right Angle Stack	Add load length & clearance	in (mm)	86.6 (2200)		86.6 (2200)		27
28	Speeds Maximum	Travel - loaded	mph (km/h)	9.0 (14.5)		9.0 (14.5)		28
29		Travel - unloaded	mph (km/h)	10.6 (17.0)		10.3 (16.5)		29
30		Lift - loaded (36v / 48v)	fpm (mm/sec)	66.0 (335)	85.7 (435)	59.1 (300)	76.8 (390)	30
31		Lift - unloaded (36v / 48v)	fpm (mm/sec)	105.3 (535)	126.0 (640)	105.3 (535)	126.0 (640)	31
32		Lowering - loaded	fpm (mm/sec)	98.5 (500)		98.5 (500)		32
33		Lowering - unloaded	fpm (mm/sec)	97.5 (495)		97.5 (495)		33
34	Drawbar Pull Maximum	Full load (36v/48v)	lb (N)	2378 (10580)	2708 (12045)	2378 (10580)	2708 (12045)	34
35	Gradeability Maximum	Full load (36v/48v)	%	20.8	24.0	18.5	21.5	35
37	Truck Weight	Empty, min battery	lb (kg)	6516 (2955)		6902 (3130)		37
38	Weight Distribution	Full load front/rear - min. battery	lb (kg)	8235 / 1279 (3735 / 580)		9050 / 1356 (4105 / 615)		38
39		No load front/rear - min. battery	lb (kg)	2756 / 3760 (1250 / 1705)		2657 / 4245 (1205 / 1925)		39
40	Tire Size	Front	in	18 x 6 x 12-1/8		18 x 6 x 12-1/8		40
41		Rear	in	14 x 5 x 10		14 x 5 x 10		41
42	Wheelbase		in (mm)	48 (1220)		48 (1220)		42
43	Tread - Center of Tire	Front / rear (standard tires)	in (mm)	32.1 / 32.3 (815 / 820)		32.1 / 32.3 (815 / 820)		43
44	Headroom	SIP to bottom of OHG	in (mm)	41.5 ( 1055 )		41.5 ( 1055 )		44
45	Counterweight Height		in (mm)	42.3 (1075)		42.3 (1075)		45
46	Step Height		in (mm)	17.3 (440)		17.3 (440)		46
47	Ground Clearance	Under mast	in (mm)	3.0 (75)		3.0 (75)		47
48		Under power unit	in (mm)	2.3 (60)		2.3 (60)		48
49		Under frame, center of wheelbase	in (mm)	3.1 (80)		3.1 (80)		49
50	Service Brake	Type		Hyd / Elec		Hyd / Elec		50
51	Parking Brake	Type		Pedal		Pedal		51
52	Steering	On-demand		Hydraulic		Hydraulic		52
53	Traction Motor	Type		AC Induction		AC Induction		53
54		Control type		MOD-INV		MOD-INV		54
55		Rating	kW/h	6.5	9.0	6.5	9.0	55
56	Pump Motor	Type		AC Induction		AC Induction		56
57		Rating	kW/5min	8.0	11.0	8.0	11.0	57
58	Required Battery Size	Minimum - W x L	in (mm)	30.12 x 20.87 (765 x 530)		30.12 x 20.87 (765 x 530)		58
59		Minimum - H	in (mm)	21.37 (542)		21.37 (542)		59
60		Maximum - W x L	in (mm)	35.15 x 26.68 (893 x 677)		35.15 x 26.68 (893 x 677)		60
61		Maximum - H	in (mm)	22.81 (579)		22.81 (579)		61
62		Lead acid (36v / 48v)	Type	18-85-19	24-85-15	18-85-19	24-85-15	62
63		Capacity - Minimum (36v / 48v)	Ah/6h	600	450	600	450	63
64		Capacity - Maximum (36v / 48v)	Ah/6h	900	700	900	700	64
65	Weight	Minimum / Maximum	lb (kg)	1840 / 2535 (835 / 1150)		1840 / 2150 (835 / 975)		65
66	Lead Length	Position B	in (mm)	18 ( 455 )		18 ( 455 )		66
67	Connector	Type		SB-350 Gray		SB-350 Gray		67

# BX Platinum series

## Dimensions

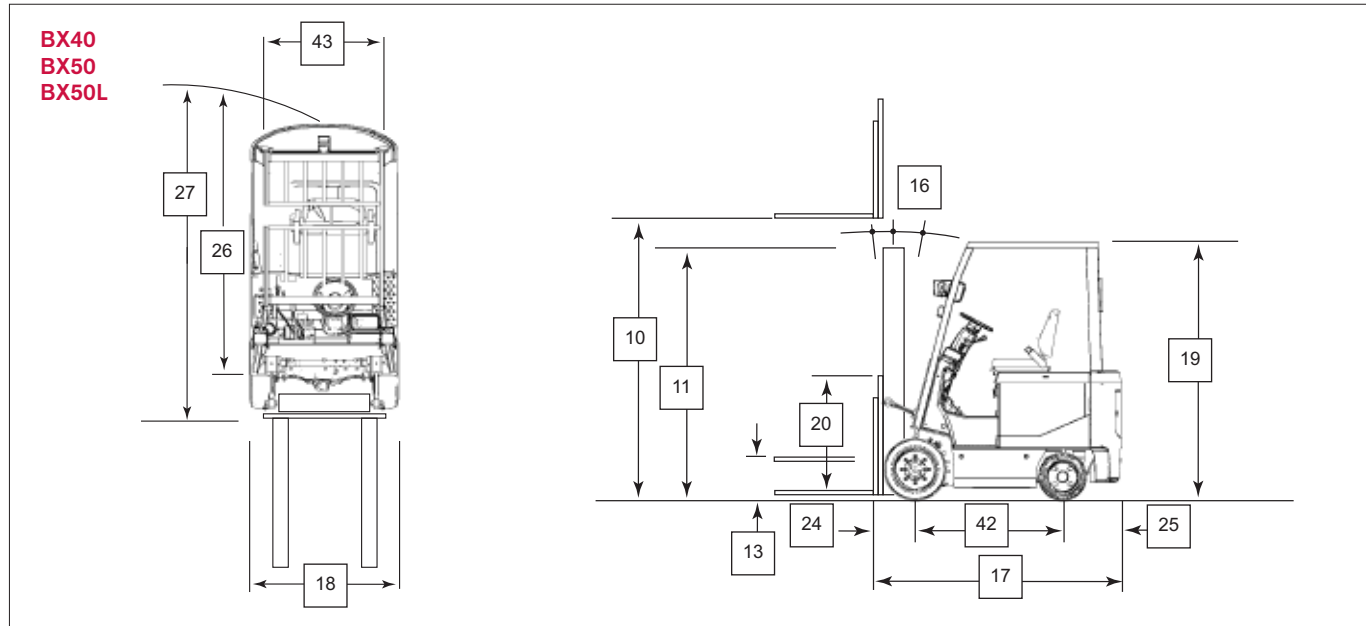

## Mast Specifications & Rated Capacities

	Mast Name	Maximum Fork Height	Overall Height Lowered	Free Lift*	Tilt angle Forward/Backward	Rated Capacity at 24" Load Center		
						BX40	BX50	BX50L
<b>TWO STAGE (Wide view 2W)</b>	2W270	106	71.3	4.2	5/10	4000	5000	5000
	2W300	118	77.2	4.2	5/10	4000	5000	5000
	2W330	130	83.1	4.2	5/10	4000	5000	5000
	2W350	138	88.4	4.2	5/10	4000	5000	5000
	2W370	146	93.3	4.2	5/10	4000	5000	5000
	2W400	157	100.8	4.2	5/10	4000	5000	5000
	2W450	177	110.6	4.2	5/5	3800	4850	4850
	2W500	197	120.5	4.2	5/5	3600	3800	3800
<b>TWO STAGE (Full free 2F)</b>	2F300	118	77.2	53.3	5/10	4000	5000	5000
	2F330	130	83.1	59.3	5/10	4000	5000	5000
	2F350	138	88.4	64.6	5/10	4000	5000	5000
	2F370	146	93.3	69.5	5/10	4000	5000	5000
	2F400	157	100.8	77.0	5/10	4000	5000	5000
<b>THREE STAGE (Full free 3F)</b>	3F385	152	71.3	48.4	5/5	4000	5000	5000
	3F430	169	77.2	54.3	5/5	3900	4850	4850
	3F475	187	83.1	60.2	5/5	3700	4700	4700
	3F515	203	88.4	65.6	5/5	3300	4250	4250
	3F550	217	93.3	70.5	5/5	3100	3700	3700
	3F600	236	100.8	78.0	5/5	2300	2400	2400
<b>THREE STAGE (Optiview 3V)</b>	3V360	142	71.3	49.4	5/5	3950	4900	4900
	3V405	159	77.2	55.3	5/5	3800	4750	4750
	3V450	177	83.1	61.2	5/5	3650	4550	4600
	3V490	193	88.4	66.5	5/5	3500	4500	4500
	3V525	207	93.3	71.5	5/5	3250	4100	4100
	3V575	226	100.8	78.9	5/5	2700	3050	3050

\*Without backrest

# 4,000 / 5,000 lb. capacities

## Main Truck Specifications

				Nissan		Nissan		Nissan				
CHARACTERISTICS	1	Manufacturer's Name		Nissan		Nissan		Nissan		1		
	2	Model	Model designation	BX40		BX50		BX50L		2		
	3		Long model code	CP1B2L20S		CP1B2L25S		CPG1B2L25S		3		
	4	Rated Load Capacity	lb (kg)	4000 (2000)		5000 (2500)		5000 (2500)		4		
	5	Load Center	Distance	in (mm)		24 (500)		24 (500)		5		
	6	Power Type	Electric	voltage	36v	48v	36v	48v	36v	48v	6	
	7	Operator Orientation		Sit		Sit		Sit		7		
DIMENSIONS	8	Tire Type	Front & rear	Cushion		Cushion		Cushion		8		
	9	Wheels	Number - front/rear (x=driven)	2x / 2		2x / 2		2x / 2		9		
	10	Mast	Maximum fork height	in (mm)		130 (3300)		130 (3300)		10		
	11		Mast lowered (OHL)	in (mm)		83.1 (2111)		83.1 (2111)		11		
	12		Mast extended with LBR	in (mm)		179.3 (4555)		179.3 (4555)		12		
	13		Standard freelif	in (mm)		4.2 (105)		4.2 (105)		13		
	14	Forks	Thickness & width	in (mm)		1.5 x 4 (40x100)		1.5 x 4 (40x100)		14		
	15		Length (STD)	in (mm)		42.1 (1070)		42.1 (1070)		15		
	16	Tilt Angle	Standard mast - fwd/back	degree		5 / 10		5 / 10		16		
	17	Overall Dimensions	Length (to face of forks)	in (mm)		84.8 (2155)		86.2 (2190)		17		
	18		Width (standard tires)	in (mm)		42.1 (1070)		42.1 (1070)		18		
	19		Height - top of OHG	in (mm)		87.4 (2220)		87.4 (2220)		19		
	20		Height - top of standard LBR	in (mm)		48.0 (1220)		48.0 (1220)		20		
	21		Width - standard carriage	in (mm)		36.2 (920)		36.2 (920)		21		
	22	Grade Clearance	Ramp breakover angle	%		31.0		31.0		22		
	23		Departure angle	%		35.0		33.0		23		
	24	Overhang	Front	in (mm)		16.7 (425)		16.7 (425)		24		
	25		Rear	in (mm)		18.5 (470)		19.9 (505)		25		
	26	Turning Radius	Minimum outside	in (mm)		72.6 (1845)		73.8 (1875)		26		
	27	Min Right Angle Stack	Add load length & clearance	in (mm)		89.3 (2270)		90.5 (2300)		27		
	PERFORMANCE	28	Speeds Maximum	Travel - loaded	mph (km/h)		10.3 (16.5)		9.3 (15.0)		28	
29		Travel - unloaded		mph (km/h)		10.6 (17.0)		10.6 (17.0)		29		
30		Lift - loaded (36v / 48v)		fpm (mm/sec)		69.0(350)	75.8(385)	63.0(320)	67.9(345)	30		
31		Lift - unloaded (36v / 48v)		fpm (mm/sec)		108.3(550)	119.1(605)	108.3(550)	119.1(605)	31		
32		Lowering - loaded		fpm (mm/sec)		98.5 (500)		98.5 (500)		32		
33		Lowering - unloaded		fpm (mm/sec)		97.5 (495)		97.5 (495)		33		
34		Drawbar Pull Maximum		Full load (36v/48v)	lb (N)		3410(15170)	3482(15490)	3410(15170)	3482(15490)	34	
35	Gradeability Maximum	Full load (36v/48v)	%		23.5	24.0	20.0	20.5	35			
WEIGHT	37	Truck Weight	Empty, min. battery	lb (kg)		8047 (3650)		8897 (4035)		37		
	38	Weight Distribution	Full load front/rear - min. battery	lb (kg)		10472 / 1576 (4750 / 715)		12049 / 1852 (5465 / 840)		38		
	39		No load front/rear - min. battery	lb (kg)		3186 / 4861 (1445 / 2205)		2944 / 5953 (1335 / 2700)		39		
	40	Tire Size	Front	in		21 x 7 x 15		21 x 7 x 15		40		
	41		Rear	in		16-1/4 x 6 x 11-1/4		16-1/4 x 6 x 11-1/4		41		
	42	Wheelbase		in (mm)		49.6 (1260)		49.6 (1260)		42		
	43	Tread - Center of Tire	Front / rear (standard tires)	in (mm)		35.0 / 35.0 (890 / 890)		35.0 / 35.0 (890 / 890)		43		
	44	Headroom	SIP to bottom of OHG	in (mm)		42.3 (1075)		42.3 (1075)		44		
	45	Counterweight Height		in (mm)		43.5 (1105)		43.5 (1105)		45		
	46	Step Height		in (mm)		18.5 (470)		18.5 (470)		46		
	47	Ground Clearance	Under mast	in (mm)		3.1 (80)		3.1 (80)		47		
48	Under power unit		in (mm)		3.9 (100)		3.9 (100)		48			
49	Under frame, center of wheelbase		in (mm)		3.7 (95)		3.7 (95)		49			
50	Service Brake	Type			Hyd / Elec		Hyd / Elec		50			
51	Parking Brake	Type			Pedal		Pedal		51			
52	Steering	On-demand			Hydraulic		Hydraulic		52			
53	Traction Motor	Type			AC Induction		AC Induction		53			
54		Control type			MOD-INV		MOD-INV		54			
55		Rating	kW/h		9.0	12.0	9.0	12.0	55			
56	Pump Motor	Type			AC Induction		AC Induction		56			
57		Rating	kW/5min		10.0	13.5	10.0	13.5	57			
BATTERY	58	Required Battery Size	Minimum - W x L	in (mm)		37.62 x 22.06 (955 x 560)		37.62 x 22.06 (955 x 560)		58		
	59		Minimum - H	in (mm)		21.37 (542)		21.37 (542)		59		
	60		Maximum - W x L	in (mm)		39.06 x 28.25 (992 x 717)		39.06 x 28.25 (992 x 717)		60		
	61		Maximum - H	in (mm)		22.81 (579)		22.81 (579)		61		
	62		Lead acid (36v / 48v)	Type		18-95-23	24-95-17	18-95-23	24-95-17	18-95-29	24-95-21	62
	63		Capacity - Minimum (36v / 48v)	Ah/6h		825	600	825	600	1050	750	63
	64		Capacity - Maximum (36v / 48v)	Ah/6h		1100	800	1100	800	1400	1000	64
	65	Weight	Minimum / Maximum	lb (kg)		2491 / 3064 (1130 / 1390)		2491 / 3064 (1130 / 1390)		3075 / 3527 (1395 / 1600)		65
	66	Lead Length	Position B	in (mm)		18 (455)		18 (455)		18 (455)		66
67	Connector		Type		SB-350 Gray		SB-350 Gray		SB-350 Gray		67	

# BX Platinum series

## Dimensions

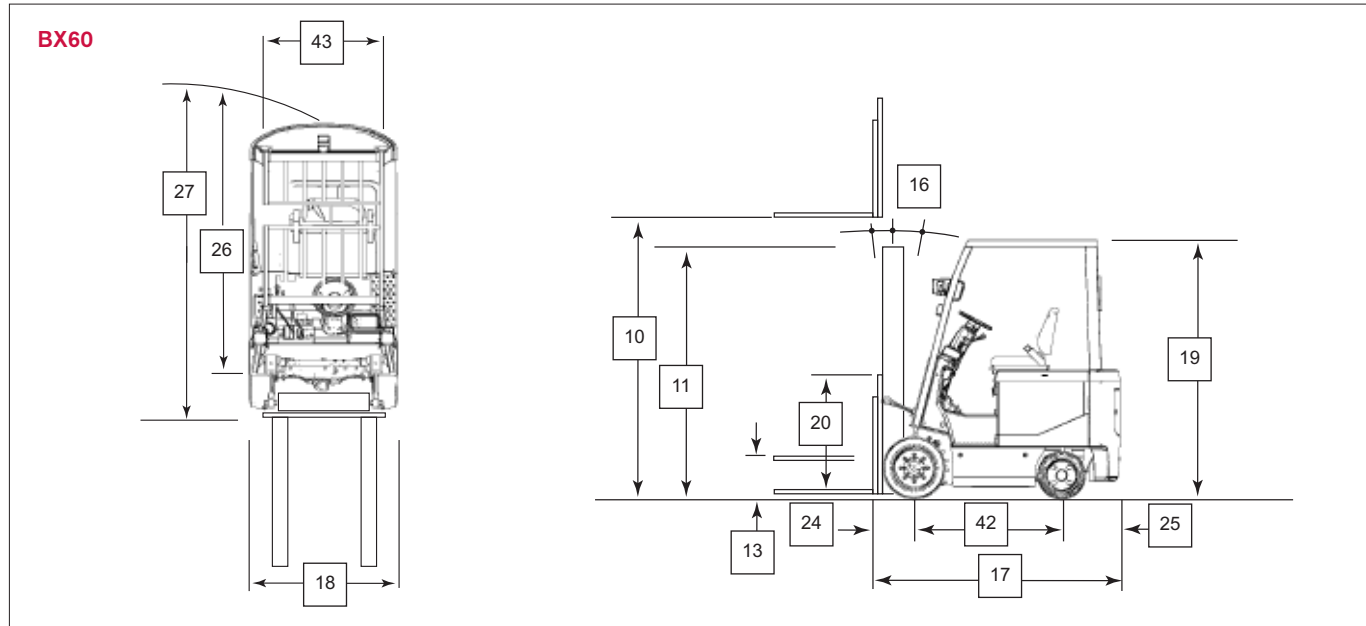

## Mast Specifications & Rated Capacities

<b>BX60</b>	Mast Name	Maximum Fork Height	Overall Height Lowered	Free Lift*	Tilt angle Forward/Backward	Rated Capacity at 24" Load Center BX60
<b>TWO STAGE (Wide view 2W)</b>	2H270	106	71.3	7.1	5/10	6000
	2H300	118	77.2	7.1	5/10	6000
	2H330	130	83.1	7.1	5/10	6000
	2H350	138	88.4	7.1	5/10	6000
	2H370	146	93.3	10.6	5/10	6000
	2H400	157	100.8	10.6	5/10	6000
	2H450	177	110.6	10.6	5/5	5750
	2H500	197	120.5	10.6	5/5	5500
<b>TWO STAGE (Full free 2F)</b>	2F300	118	77.2	53.0	5/10	6000
	2F330	130	83.1	58.9	5/10	6000
	2F350	138	88.4	64.2	5/10	6000
	2F370	146	93.3	69.1	5/10	6000
	2F400	157	100.8	76.6	5/10	6000
<b>THREE STAGE (Full free 3F)</b>	3F385	152	77.2	53.0	5/5	6000
	3F430	169	83.1	58.9	5/5	5700
	3F475	187	88.4	64.2	5/5	5550
	3F515	203	93.3	69.1	5/5	5200
	3F550	217	100.8	76.6	5/5	4850
	3F600	236	110.6	86.4	5/5	3100
<b>THREE STAGE (Optiview 3V)</b>	3V385	152	77.2	53.0	5/5	5650
	3V430	169	83.1	58.9	5/5	5450
	3V470	185	88.4	64.2	5/5	5300
	3V505	199	93.3	69.1	5/5	5000
	3V555	219	100.8	76.6	5/5	4500

\*Without backrest

# 6,000 lb. capacity

## Main Truck Specifications

CHARACTERISTICS	1	Manufacturer's Name		Nissan		1	
	2	Model	Model designation	BX60		2	
	3		Long model code	CPG1B2L30S		3	
	4	Rated Load Capacity		lb (kg)	6000 (3000)		4
	5	Load Center	Distance	in (mm)	24 (500)		5
	6	Power Type	Electric	voltage	36v	48v	6
	7	Operator Orientation			Sit		7
DIMENSIONS	8	Tire Type	Front & rear	Cushion		8	
	9	Wheels	Number - front/rear (x=driven)	2x / 2		9	
	10	Mast	Maximum fork height	in (mm)	130 (3300)		10
	11		Mast lowered (OHL)	in (mm)	83.1 (2111)		11
	12		Mast extended with LBR	in (mm)	179.3 (4555)		12
	13		Standard freelif	in (mm)	7.1 (180)		13
	14	Forks	Thickness & width	in (mm)	2 x 5 (50x125)		14
	15		Length (STD)	in (mm)	42.1 (1070)		15
	16	Tilt Angle	Standard mast - fwd/back	degree	5 / 10		16
	17	Overall Dimensions	Length (to face of forks)	in (mm)	93.1 (2365)		17
	18		Width (standard tires)	in (mm)	43.3 (1100)		18
	19		Height - top of OHG	in (mm)	87.4 (2220)		19
	20		Height - top of standard LBR	in (mm)	48.0 (1220)		20
	21		Width - standard carriage	in (mm)	40.2 (1020)		21
	22	Grade Clearance	Ramp breakover angle	%	27.0		22
	23		Departure angle	%	28.0		23
	24	Overhang	Front	in (mm)	16.7 (425)		24
	25		Rear	in (mm)	22.8 (580)		25
	26	Turning Radius	Minimum outside	in (mm)	81.1 (2060)		26
	27	Min Right Angle Stack	Add load length & clearance	in (mm)	97.8 (2485)		27
	PERFORMANCE	28	Speeds Maximum	Travel - loaded	mph (km/h)	8.7 (14.0)	
29		Travel - unloaded		mph (km/h)	9.3 (15.0)		29
30		Lift - loaded (36v / 48v)	fpm (mm/sec)	50.2 (255)	55.1 (280)		30
31		Lift - unloaded (36v / 48v)	fpm (mm/sec)	92.5 (470)	101.4 (515)		31
32		Lowering - loaded	fpm (mm/sec)	98.5 (500)			32
33		Lowering - unloaded	fpm (mm/sec)	97.5 (495)			33
34		Drawbar Pull Maximum	Full load (36v/48v)	lb (N)	3924 (17455)	4007 (17825)	
35	Gradeability Maximum	Full load (36v/48v)	%	19.5	20.0		35
WEIGHT	37	Truck Weight	Empty, min. battery	lb (kg)	10419 (4725)		37
	38	Weight Distribution	Full load front/rear - min. battery	lb (kg)	14275 / 2139 (6475 / 970)		38
	39		No load front/rear - min. battery	lb (kg)	3594 / 6825 (1630 / 3095)		39
CHASSIS & WHEELS	40	Tire Size	Front	in	22 x 8 x 16		40
	41		Rear	in	16-1/4 x 6 x 11-1/4		41
	42	Wheelbase		in (mm)	53.5 (1360)		42
	43	Tread - Center of Tire	Front / rear (standard tires)	in (mm)	35.2 / 35.0 (895 / 890)		43
	44	Headroom	SIP to bottom of OHG	in (mm)	42.3 (1075)		44
	45	Counterweight Height		in (mm)	43.5 (1105)		45
	46	Step Height		in (mm)	18.5 (470)		46
	47	Ground Clearance	Under mast	in (mm)	3.1 (80)		47
	48		Under power unit	in (mm)	3.7 (95)		48
	49		Under frame, center of wheelbase	in (mm)	3.5 (90)		49
	50	Service Brake	Type		Hyd / Elec		50
51	Parking Brake	Type		Pedal		51	
DRIVE LINE	52	Steering	On-demand		Hydraulic		52
	53	Traction Motor	Type		AC Induction		53
	54		Control type		MOD-INV		54
	55		Rating	kW/h	9.0	12.0	55
	56	Pump Motor	Type		AC Induction		56
57	Rating		kW/5min	10.0	13.5		57
BATTERY	58	Required Battery Size	Minimum - W x L	in (mm)	37.62 x 28.56 (955 x 725)		58
	59		Minimum - H	in (mm)	21.37 (542)		59
	60		Maximum - W x L	in (mm)	39.06 x 34.12 (992 x 866)		60
	61		Maximum - H	in (mm)	22.81 (579)		61
	62		Lead acid (36v / 48v)	Type	18-95-29	24-95-21	62
	63		Capacity - Minimum (36v / 48v)	Ah/6h	1050	750	63
	64		Capacity - Maximum (36v / 48v)	Ah/6h	1400	1000	64
65	Weight	Minimum / Maximum	lb (kg)	3075 / 3527 (1395 / 1600)		65	
66	Lead Length	Position B	in (mm)	18 (455)		66	
67	Connector		Type	SB-350 Gray		67	

# BX Platinum series

## Dimensions

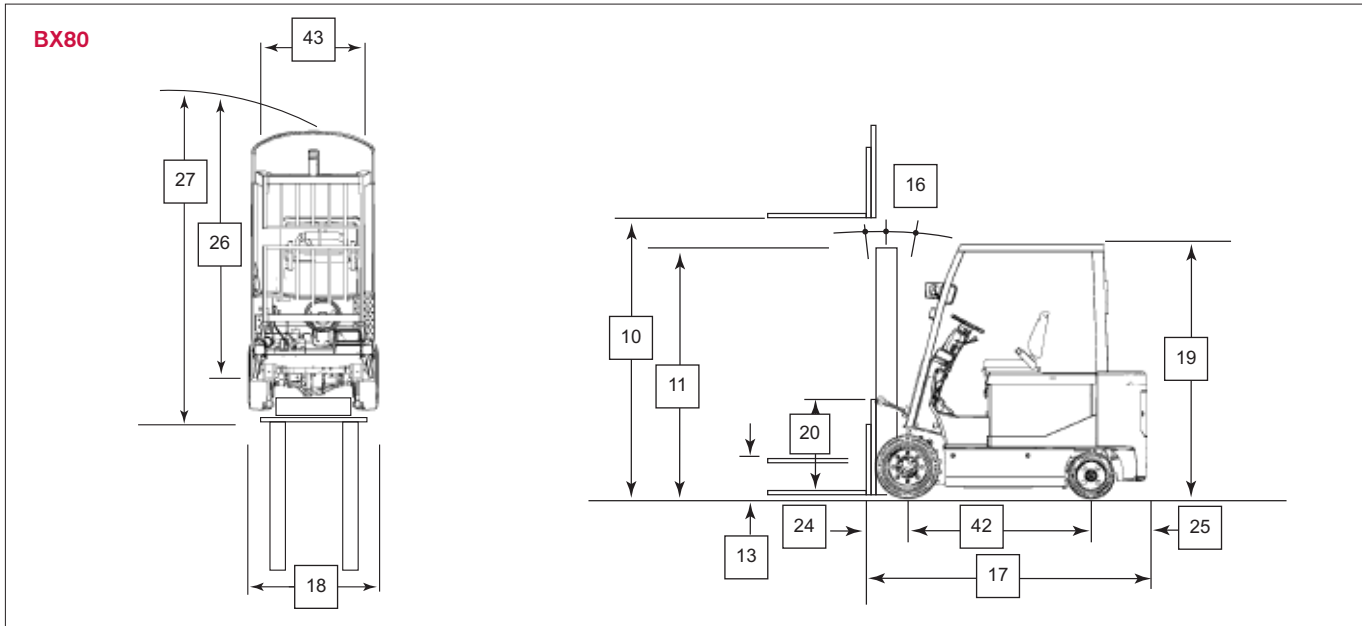

## Mast Specifications & Rated Capacities

BX80	Mast Name	Maximum Fork Height	Overall Height Lowered	Free Lift*	Tilt angle Forward/Backward	Rated Capacity at 24" Load Center BX80
TWO STAGE (Wide view 2W)	2H280	110	77.2	7.1	5/10	8000
	2H310	122	83.1	7.1	5/10	8000
	2H350	138	93.3	10.6	5/10	8000
	2H380	150	100.8	10.6	5/10	8000
	2H430	169	110.6	10.6	5/10	8000
TWO STAGE (Full free 2F)	2F280	110	77.2	51.0	5/10	8000
	2F310	122	83.1	56.9	5/10	8000
	2F350	138	93.3	67.1	5/10	8000
	2F380	150	100.8	74.6	5/10	8000
THREE STAGE (Full free 3F)	3F400	157	77.2	51.0	5/5	8000
	3F445	175	83.1	56.9	5/5	7700
	3F485	191	88.4	62.2	5/5	7550
	3F520	205	93.3	67.1	5/5	7200
	3F570	224	100.8	74.6	5/5	6850
THREE STAGE (Optview 3V)	3V385	152	77.2	52.2	5/5	7650
	3V430	169	83.1	58.1	5/5	7450
	3V470	185	88.4	63.4	5/5	7300
	3V505	199	93.3	68.3	5/5	7000
	3V555	219	100.8	75.8	5/5	6500

\* Without backrest



# 8,000 lb. capacity

## Main Truck Specifications

CHARACTERISTICS				Nissan				
1	Manufacturer's Name			Nissan		1		
2	Model	Model designation		BX80		2		
3		Long model code		CPG1B2L35S		3		
4	Rated Load Capacity		lb (kg)	8000 (4000)		4		
5	Load Center	Distance	in (mm)	24 (500)		5		
6	Power Type	Electric	voltage	36v	48v	6		
7	Operator Orientation			Sit		7		
DIMENSIONS	8	Tire Type	Front & rear	Cushion		8		
	9	Wheels	Number - front/rear (x=driven)	2x / 2		9		
	10	Mast	Maximum fork height	in (mm)	138 (3500)		10	
	11		Mast lowered (OHL)	in (mm)	93.3 (2370)		11	
	12		Mast extended with LBR	in (mm)	187.2 (4755)		12	
	13		Standard freelif	in (mm)	10.6 (270)		13	
	14	Forks	Thickness & width	in (mm)	2 x 5 (50x125)		14	
	15		Length (STD)	in (mm)	42.1 (1070)		15	
	16	Tilt Angle	Standard mast - fwd/back	degree	5 / 10		16	
	17	Overall Dimensions	Length (to face of forks)	in (mm)	99.0 (2515)		17	
	18		Width (standard tires)	in (mm)	43.3 (1100)		18	
	19		Height - top of OHG	in (mm)	87.4 (2220)		19	
	20		Height - top of standard LBR	in (mm)	48.0 (1220)		20	
	21		Width - standard carriage	in (mm)	40.2 (1020)		21	
	22	Grade Clearance	Ramp breakover angle	%	23.0		22	
	23		Departure angle	%	33.0		23	
	24	Overhang	Front	in (mm)	16.7 (425)		24	
	25		Rear	in (mm)	19.3 (490)		25	
	26	Turning Radius	Minimum outside	in (mm)	88.4 (2245)		26	
	27	Min Right Angle Stack	Add load length & clearance	in (mm)	105.1 (2670)		27	
	PERFORMANCE	28	Speeds Maximum	Travel - loaded	mph (km/h)	7.8 (12.5)		28
29		Travel - unloaded		mph (km/h)	9.0 (14.5)		29	
30		Lift - loaded (36v / 48v)	fpm (mm/sec)	43.3 (220)	46.3 (235)		30	
31		Lift - unloaded (36v / 48v)	fpm (mm/sec)	77.8 (395)	84.7 (430)		31	
32		Lowering - loaded	fpm (mm/sec)	98.5 (500)			32	
33		Lowering - unloaded	fpm (mm/sec)	97.5 (495)			33	
34		Drawbar Pull Maximum	Full load (36v/48v)	lb (N)	3924 (17455)	4007 (17825)		34
35	Gradeability Maximum	Full load (36v/48v)	%	16.5	16.5		35	
WEIGHT	37	Truck Weight	Empty, min. battery	lb (kg)	12203 (5535)		37	
	38	Weight Distribution	Full load front/rear - min. battery	lb (kg)	17891 / 2315 (8115 / 1050)		38	
	39		No load front/rear - min. battery	lb (kg)	4564 / 7639 (2070 / 3465)		39	
CHASSIS & WHEELS	40	Tire Size	Front	in	22 x 8 x 16		40	
	41		Rear	in	16-1/4 x 6 x 11-1/4		41	
	42	Wheelbase		in (mm)	63.0 (1600)		42	
	43	Tread - Center of Tire	Front / rear (standard tires)	in (mm)	35.2 / 35.0 (895 / 890)		43	
	44	Headroom	SIP to bottom of OHG	in (mm)	42.3 (1075)		44	
	45	Counterweight Height		in (mm)	43.5 (1105)		45	
	46	Step Height		in (mm)	18.5 (470)		46	
	47	Ground Clearance	Under mast	in (mm)	3.1 (80)		47	
	48		Under power unit	in (mm)	3.7 (95)		48	
	49		Under frame, center of wheelbase	in (mm)	3.5 (90)		49	
	50	Service Brake	Type		Hyd / Elec		50	
51	Parking Brake	Type		Pedal		51		
52	Steering	On-demand		Hydraulic		52		
DRIVE LINE	53	Traction Motor	Type		AC Induction		53	
	54		Control type		MOD-INV		54	
	55		Rating	kW/h	9.0	12.0		55
	56	Pump Motor	Type		AC Induction		56	
57	Rating		kW/5min	10.0	13.5		57	
BATTERY	58	Required Battery Size	Minimum - W x L	in (mm)	37.62 x 28.56 (955 x 725)		58	
	59		Minimum - H	in (mm)	21.37 (542)		59	
	60		Maximum - W x L	in (mm)	39.06 x 34.12 (992 x 866)		60	
	61		Maximum - H	in (mm)	22.81 (579)		61	
	62		Lead acid (36v / 48v)	Type	18-95-29	24-95-21		62
	63		Capacity - Minimum (36v / 48v)	Ah/6h	1200	1000		63
	64		Capacity - Maximum (36v / 48v)	Ah/6h	1400	1200		64
	65		Weight	Minimum / Maximum	lb (kg)	3351 / 3527 (1520 / 1600)		65
	66	Lead Length	Position B	in (mm)	18 (455)		66	
	67	Connector	Type		SB-350 Gray		67	

\* 2W330 mast, less forks

# Available Equipment

---

## Standard Equipment

---

- 36/48-volt electrical system
- 100% brushless AC-drive, lift and steering systems
- Nissan AC TECH controller works in conjunction with built-in test equipment and multifunction LCD display to provide on-board diagnostics, self-test and service history
- Flex-Logic Acceleration Control
- AC-powered hydraulic pump motor and drive motor
- Load sensing on-demand AC controlled hydraulic power steering
- Three pre-set standard performance modes—economy, normal and high performance settings along with a manual setting, allows complete application and performance flexibility.
- U.L. “ES” rated electrical system
- Nissan's Safety System includes seat-actuated power interrupt system, seat belt warning buzzer and parking brake warning buzzer
- Cushioned stability control
- Secure, pin number access to personalized performance settings
- Exclusive single lift and tilt control lever provides greater opportunity for increased productivity
- Five-mode regenerative braking system
- Controlled rollback feature reduces truck descent speed while on incline
- Infinitely adjustable steer column with small diameter steering wheel
- Full suspension, fold down cloth seat with operator restraint system and locking retractor seat belt
- Audible back-up warning alarm
- Overhead guard mounted headlights
- Five-piece reinforced overhead guard
- Auto-Power off
- Foot operated parking brake

---

## Optional Equipment

---

- Nissan exclusive three-stage Optiview mast with 50% greater visibility
- Standard or polished and tapered forks in a variety of lengths
- Side shifters with auxiliary hydraulics, valving, and levers
- Single or dual IHR for all mast types
- Separate lift/tilt control levers
- Hydraulic accumulator in the lift system
- Traction, or smooth, non-marking tires
- Battery compartment rollers
- Magnetic convenience tray
- Rearview mirrors
- Steering wheel spinner knob
- Turn, stop and backup lights
- Rear work light
- Strobe light
- Fire extinguisher
- U.L. “EE” rated electrical system
- Freezer package for operating environments as low as -31°F (-35°C)
- Overhead guard modified for drive-in racking
- Higher and lower overhead guard settings

# Technical Information 4-wheel AC-powered models

---

## Operator Enhanced Comfort and Productivity

The BX Platinum Series offers a variety of operator conveniences for enhanced comfort and increased productivity, including a full suspension cloth seat with weight and back-angle adjustment, hip restraint and retractable seat belt. A compact front cowl design offers generous leg and foot room along with a wide entry step. Its infinitely adjustable steering column enhances operator comfort.

The BX Platinum Series' AC TECH controller offers Flex-logic acceleration control which enables the truck to respond according to the speed with which the pedal is depressed, allowing more accurate, precise control by the driver. The hydraulic, AC powered, steering system reduces operator effort, for easier maneuvering, while a hydraulic load sensing valve diverts fluid for priority to the steering system.

The standard, Nissan exclusive, single lift/tilt control lever design offers enhanced ergonomics and improved productivity. Separate lift and tilt hydraulic control levers are optional.

The LCD dash display visibly communicates truck status and warnings for operator awareness including: travel speed, battery capacity, hour meter (4-mode), time and day of week, brake warning, seat belt warning, and selected power mode.

The BX Platinum Series' Safety System includes: Mast Lock (automatically locking mast lift and tilt when the operator leaves the seat), Cushioned Stability Control (incorporates a maintenance-free rubber damper between the rear axle and body to enhance lateral stability under normal driving conditions), and Controlled Rollback (reducing quick truck movement down a gradient, when the accelerator is released).

---

## Features for Increased Efficiency

The BX Platinum Series' AC TECH controller provides lower battery consumption and optimum operating efficiencies through regenerative braking, automatic deceleration, and on-demand power steering. Five-mode regenerative braking system increases the number of working hours per battery charge. An adjustable auto-power off feature will switch off the electrical system if the truck sits idle for a predetermined time period.

A four-digit PIN code offers access to adjustable performance settings, allowing up to five unique operational profiles according to driver experience and load handling conditions. Or, select from three preset performance modes (economy, normal, high) based on the application. If additional flexibility is needed you can manually adjust settings to meet application needs.

---

## Battery and Electrical

Available with an "ES" rated 36 or 48 volt electrical system. The AC TECH motor controller features MOS-FET power inverters for DC to three phase AC power conversion. Single contactor design reduces maintenance.

---

## Brake System

Regenerative braking is achieved through switch-back/plugging, foot applied braking, neutral braking, controlled roll back and lift lever stopping. Reduced height brake pedal improves the ease of operation and reduces operator fatigue. Automatic, programmable deceleration prolongs battery life. An automotive feel and lower operating force are realized by a foot-actuated parking brake, with lock release button located on the cowl within easy reach.

---

## Truck and Mast Design

The BX Platinum Series' rugged, unitized frame design incorporates an integral hydraulic tank for better heat dissipation, increased durability, and longer life. Contoured counterweight design enhances maneuverability.

Five-piece reinforced overhead guard design allows easy replacement should individual parts become damaged. Slotted design facilitates overhead battery replacement.

Nissan's flat face mast design features rolled steel channels, large cross sections, and thick inner rails for increased capacity retention. Side thrust rollers on the fork carriage are easily accessed for carriage adjustment. Optional Nissan exclusive Optiview, three-stage mast design offers 50% greater visibility for improved load handling.

---

## Drive Unit

Free floating drive axle with lateral mounted AC drive motor offers more power and quicker response. Quieter, more efficient helical gearing reduces noise levels and increases durability. Service brakes are standard shoe type.

---

## Hydraulics

Powerful AC hydraulic pump motor powers lift and tilt operation as well as the on-demand power steering system. Hydraulic operation is infinitely variable through the AC TECH controller.

---

## Reduced Maintenance

The BX Platinum Series features a 100% AC-powered system, including brushless drive motor and hydraulic pump motor. On-demand steering achieved through priority hydraulic load sensing valve, eliminating use of a separate steering motor. The design greatly reduces the number of serviceable parts, including commutators, contactors, and brushes; eliminating expenses related to inspection and replacement of these items, for lower overall operating costs.

The AC TECH controller includes a built-in-test-equipment module with self-diagnostics and coded service history, logged by hour meter reading. Troubleshooting through the instrument panel allows rapid access to service requirements. No additional handset tool is required. Hydraulic oil tank filler location makes daily level checks and periodic refills fast and simple.

# **TOTAL** **WAREHOUSE**

[www.totalwarehouse.com](http://www.totalwarehouse.com)

833-868-2500

*Nissan Forklift Corporation reserves the right to make product changes relating to colors, equipment or specifications without notice. For more information, contact your Nissan Forklift representative.*

**NISSAN**  
**FORKLIFT**