

UNICARRIERS[®] TOTAL WAREHOUSE

□ FORKLIFT □ www.totalwarehouse.com
833-868-2500

SCX Series



Standup Counterbalanced Forklifts

36 Volt AC-Powered

3,000 / 3,500 / 4,000 lbs. Capacities | Cushion Tire



S P E C I F I C A T I O N S

MAIN TRUCK SPECIFICATIONS

CHARACTERISTICS	1	Manufacturer's Name		UniCarriers	UniCarriers	UniCarriers	UniCarriers		
	2	Model	Model designation	SCX30SN	SCX30N	SCX35N	SCX40N		
	3	Long model code		S1S1L15NV	1S1L15NV	1S1L18NV	1S1L20NV		
	4	Rated Load Capacity	lb (kg)	3000 (1500)	3000 (1500)	3500 (1800)	4000 (2000)		
	5	Load Center	Distance	in (mm)	24 (600)	24 (600)	24 (600)	24 (600)	
	6	Power Type	Electric	voltage	36v	36v	36v	36v	
	7	Operator Orientation			Stand Up	Stand Up	Stand Up	Stand Up	
DIMENSIONS	8	Tire Type	Front & rear		Cushion Poly	Cushion Poly	Cushion Poly	Cushion Poly	
	9	Wheels	Number front / rear (x=driven)		2 x / 2	2 x / 2	2 x / 2	2 x / 2	
	10	Mast	Maximum fork height	in (mm)	130 (3300)	130 (3300)	130 (3300)	130 (3300)	
	11		Mast lowered (OHL)	in (mm)	83.2 (2110)	83.2 (2110)	83.2 (2110)	83.2 (2110)	
	12		Mast extended with LBR	in (mm)	179.3 (4555)	179.3 (4555)	179.3 (4555)	179.3 (4555)	
	13		Standard freelif	in (mm)	3.8 (95)	3.8 (95)	3.8 (95)	3.8 (95)	
	14		Mast width (rail width)	in (mm)	24.8 (630)	24.8 (630)	24.8 (630)	24.8 (630)	
	15	Forks	Length x width x thickness	in (mm)	42 x 4 x 1.5 (420 x 100 x 40)				
	16	Tilt Angle	Standard mast - fwd/back	degree	3/5	3/5	3/5	3/5	
	17	Overall Dimensions	Length - to face of forks	in (mm)	66 (1680)	68.2 (1735)	68.2 (1735)	70.5 (1790)	
	18		Width (standard tires)	in (mm)	42.5 (1080)	42.5 (1080)	42.5 (1080)	42.5 (1080)	
	19		Height - top of OHG	in (mm)	86.8 (2205)	86.8 (2205)	86.8 (2205)	86.8 (2205)	
	20		Height - top of standard LBR	in (mm)	48 (1220)	48 (1220)	48 (1220)	48 (1220)	
	21		Width - standard carriage	in (mm)	36.2 (920)	36.2 (920)	36.2 (920)	36.2 (920)	
	22	Grade Clearance	Ramp breakover angle	%	43.3	40.8	40.8	38.4	
	23		Departure angle	%	41	41	41	41	
	24	Overhang	Front / Rear	in (mm)	14.6 / 10.3 (370 / 260)	14.6 / 10.3 (370 / 260)	14.6 / 10.3 (370 / 260)	14.6 / 10.3 (370 / 260)	
	25	Turning Radius	Minimum outside	in (mm)	52.3 (1330)	54.5 (1385)	54.5 (1385)	56.8 (1445)	
	26	Min Right Angle Stack	Add load length & clearance	in (mm)	66.9 (1700)	69.1 (1755)	69.1 (1755)	71.4 (1815)	
	PERFORMANCE	27	Speeds Maximum	Travel - loaded / unloaded	mph (km/h)	7.8 / 8.0 (12.6 / 12.9)	7.8 / 8.0 (12.6 / 12.9)	7.8 / 8.0 (12.6 / 12.9)	7.8 / 8.0 (12.6 / 12.9)
		28		Lift - loaded / unloaded	fpm (mm/sec)	71 / 114 (362 / 577)	71 / 114 (362 / 577)	66 / 114 (334 / 577)	62 / 114 (317 / 577)
29			Lowering - loaded / unloaded	fpm (mm/sec)	92 / 93 (469 / 472)	92 / 93 (469 / 472)	91 / 93 (463 / 472)	93 / 93 (470 / 472)	
30		Gradeability Maximum	Full load	%	29.1	27.6	26.9	26.1	
WEIGHT	31	Truck Weight	No Load (min battery)	lb (kg)	8160 (3700)	7715 (3500)	8585 (3895)	9090 (4125)	
	32	Weight Distribution	Full load - min. battery - front	lb (kg)	9575 (4340)	9225 (4185)	10285 (4665)	11190 (5075)	
	33		Full load - min. battery - rear	lb (kg)	1585 (720)	1490 (675)	1795 (815)	1900 (860)	
	34		No load - min. battery - front	lb (kg)	3900 (1765)	3670 (1665)	3800 (1725)	3945 (1790)	
	35		No load - min. battery - rear	lb (kg)	4260 (1935)	4045 (1835)	4785 (2170)	5145 (2335)	
CHASSIS & WHEELS	36	Tire Size	Front	in (mm)	18 x 7 x 12-1/8	18 x 7 x 12-1/8	18 x 7 x 12-1/8	18 x 7 x 12-1/8	
	37		Rear	in (mm)	10 x 5 x 6-1/2	10 x 5 x 6-1/2	10 x 5 x 6-1/2	10 x 5 x 6-1/2	
	38	Wheelbase		in (mm)	41.8 (1065)	43.9 (1115)	43.9 (1115)	46.3 (1175)	
	39	Tread - Center of Tire	Front / rear	in (mm)	35.5 / 5.3 (900 / 135)	35.5 / 5.3 (900 / 135)	35.5 / 5.3 (900 / 135)	35.5 / 5.3 (900 / 135)	
	40	OHG Post Spread	Outside-to-outside	in (mm)	24 (610)	24 (610)	24 (610)	24 (610)	
	41	Chassis Height		in (mm)	57.5 (1460)	57.5 (1460)	57.5 (1460)	57.5 (1460)	
	42	Headroom	Floor to bottom of OHG	in (mm)	75.8 (1925)	75.8 (1925)	75.8 (1925)	75.8 (1925)	
	43	Ground Clearance	Lowest point	in (mm)	2.1 (55)	2.1 (55)	2.1 (55)	2.1 (55)	
	44		Under frame, center of wheelbase	in (mm)	4.0 (100)	4.0 (100)	4.0 (100)	4.0 (100)	
	45	Service Brake	Type		Regen	Regen	Regen	Regen	
46	Parking Brake	Type		Auto-Applied / Electronic Release		Auto-Applied / Electronic Release			
DRIVE LINE	47	Steering	On-demand		Hydraulic	Hydraulic	Hydraulic	Hydraulic	
	48	Traction Motor	Type		AC Induction	AC Induction	AC Induction	AC Induction	
	49		Control type		AC Inverter	AC Inverter	AC Inverter	AC Inverter	
	50	Pump Motor	Type		AC Induction	AC Induction	AC Induction	AC Induction	
	51	Hydraulic Control			Electroproportional	Electroproportional	Electroproportional	Electroproportional	
BATTERY	52	Battery Compartment Size	W x H - Maximum	in (mm)	38.5 x 32 (975 x 810)			38.5 x 32 (975 x 810)	
	53		L - Maximum	in (mm)	16.3 (415)	18.4 (465)	18.4 (465)	20.8 (530)	
	54	Battery	Lead acid	Type	18-125-13	18-125-15	18-125-15	18-125-17	
	55		Max. Capacity - 6 hr. rating	Ah	930	1085	1085	1240	
	56	Weight	Minimum / Maximum	lb (kg)	1885 / 2400 (855 / 1085)	2175 / 2700 (990 / 1225)	2175 / 2700 (990 / 1225)	2460 / 3000 (1115 / 1360)	
	57	Lead Length	Position B / SB-350 Gray	in (mm)	24 (610)	24 (610)	24 (610)	24 (610)	

MAST SPECIFICATIONS & RATED CAPACITIES

Mast Name	Maximum Fork Height	Overall Height				Free Lift		Tilt Angle	Rated Capacity at 24" (610) Load Center with 42" (1070mm) I.D. Outriggers			
		Lowered	Fully Extended		With LBR	Without LBR	Fwd/ Bkwd		SCX30S	SCX30	SCX35	SCX40
		MHL	OHL	With LBR				Without LBR				
		in (mm)	in (mm)	in (mm)	in (mm)	in (mm)	in (mm)					
TWO STAGE (Wide View)	2W270	106 (2700)	71.3 (1810)	155.7 (3955)	130.0 (3305)	3.8 (95)	3.8 (95)	3/5	3000 (1360)	3000 (1360)	3500 (1585)	4000 (1810)
	2W300	118 (3000)	77.2 (1960)	167.5 (4255)	141.9 (3605)	3.8 (95)	3.8 (95)	3/5	3000 (1360)	3000 (1360)	3500 (1585)	4000 (1810)
	2W330	130 (3300)	83.1 (2115)	179.3 (4555)	153.7 (3905)	3.8 (95)	3.8 (95)	3/5	3000 (1360)	3000 (1360)	3500 (1585)	4000 (1810)
	2W350	138 (3500)	88.5 (2250)	187.2 (4755)	161.5 (4105)	3.8 (95)	3.8 (95)	3/5	3000 (1360)	3000 (1360)	3500 (1585)	4000 (1810)
THREE STAGE (Full Free)	3F385	152 (3850)	71.3 (1810)	200.9 (5105)	168.3 (4275)	23.3 (590)	46.9 (1190)	4/4	3000 (1360)	3000 (1360)	3500 (1585)	4000 (1810)
	3F430	169 (4300)	77.2 (1960)	218.7 (5555)	186.0 (4725)	29.2 (740)	52.8 (1340)	3/5	3000 (1360)	3000 (1360)	3500 (1585)	4000 (1810)
	3F475	187 (4750)	83.1 (2110)	236.4 (6005)	203.7 (5175)	35.1 (890)	58.7 (1490)	3/5	3000 (1360)	3000 (1360)	3500 (1585)	4000 (1810)
	3F515	203 (5150)	88.5 (2250)	252.3 (6410)	219.7 (5580)	40.4 (1025)	64.0 (1625)	3/5	2950 (1335)	2950 (1335)	3475 (1575)	3675 (1665)
	3F550	217 (5500)	93.4 (2375)	265.9 (6755)	233.3 (5925)	45.3 (1150)	68.9 (1750)	3/5	2900 (1315)	2900 (1315)	3350 (1515)	3425 (1550)
	3F600	236 (6000)	100.9 (2565)	285.6 (7255)	253.0 (6425)	52.8 (1340)	76.4 (1940)	3/5	2800 (1265)	2800 (1265)	3150 (1425)	3150 (1425)
	3F650	256 (6500)	110.7 (2810)	305.3 (7755)	275.8 (7005)	62.6 (1590)	86.2 (2190)	3/5	2725 (1235)	2725 (1235)	2900 (1315)	2900 (1315)
	3F700	276 (7000)	120.6 (3065)	325.0 (8255)	297.4 (7555)	72.5 (1840)	96.1 (2440)	3/5	2625 (1190)	2625 (1190)	2700 (1220)	2700 (1220)

DIMENSIONS

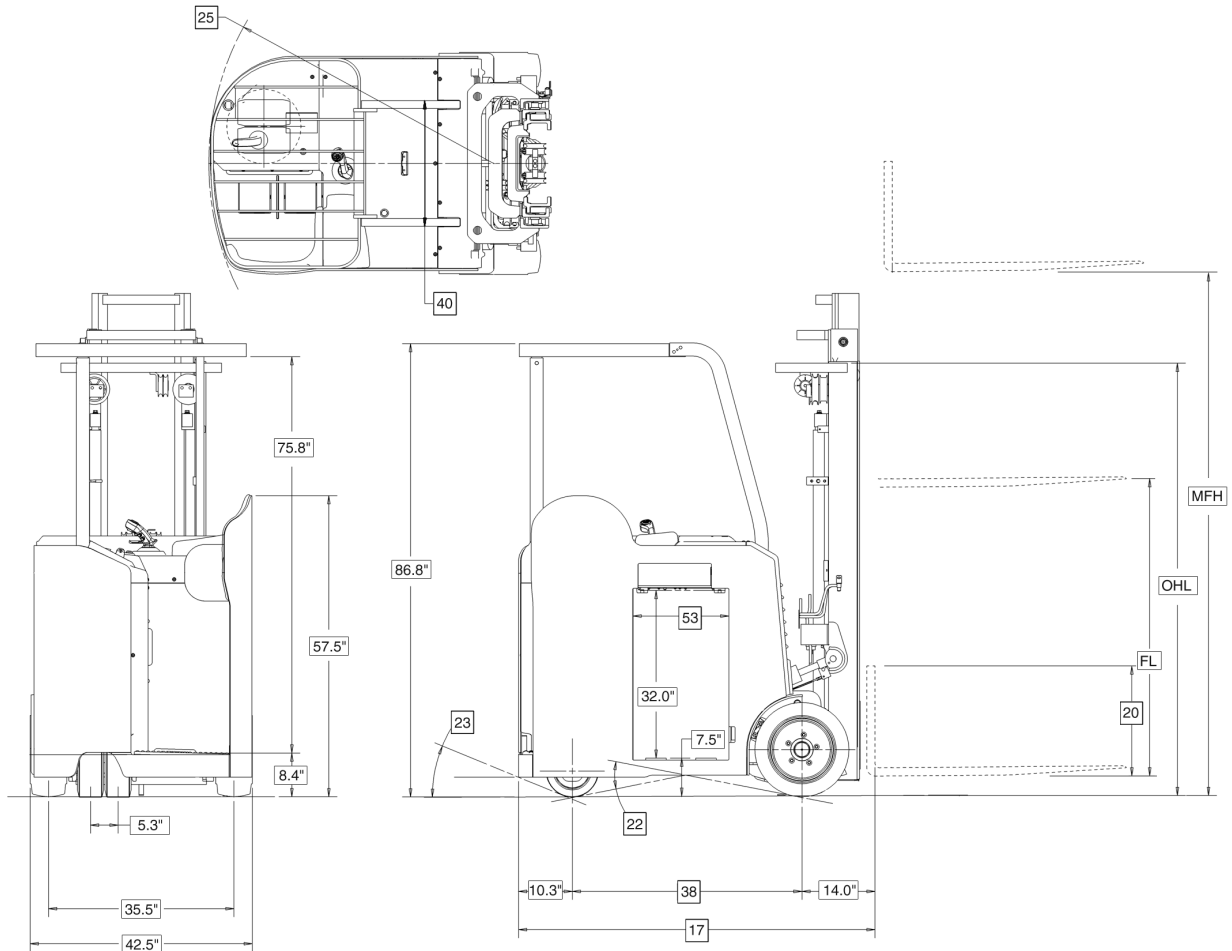

STANDARD EQUIPMENT

- 36-Volt, brushless AC-powered hydraulic pump motor and dual drive motors
- AC TECH motor controller system
- 3 pre-set performance modes (Economy, Power, High)
- 1 Manual (custom) performance mode
- Secure, PIN access to personalized performance settings
- 4-mode regenerative braking
- Side stance operator compartment
- Ergonomically sloped floorboard with vibration isolators
- Cushioned floor mat, back and armrest padding
- Multi-function LCD:
 - Hour meters (4)
 - Operator PIN security access
 - On-board diagnostics
 - Steer tire position indicator
 - Parking brake indicator lamp
 - Operator presence indicator
 - Speedometer
 - BDI with lift interrupt
- On-board diagnostics, self-test and error code history
- Multi-function control handle
- On-demand priority hydraulic power steering with small diameter steer tiller
- Operator Presence System with return-to-neutral and mast lockout
- Auto-Power off system
- Emergency button
- Electro-magnetic parking brake with anti-rollback
- Reduced speeds and restricted tilt above freelif
- Four-piece overhead guard
- Battery compartment rollers and side gates
- UL "E" rated electrical system

OPTIONAL EQUIPMENT

- Fan and compartment light package
- High visibility carriage
- Tilt cylinder boots
- Cushioned knee pad
- Hang-on and integral sidershifters
- Extra forward tilt
- Freezer package (to -22°F / -30°C)
- Rear LED work light
- Overhead guard mounted LED headlights
- Strobe light
- Travel alarm
- Reverse steering
- U.L. "EE" rated electrical system
- Fire extinguisher
- Overhead guard modifications
- Micro-siped tires
- Standard, or polished and tapered, forks in a variety of lengths
- Single or dual IHR for all available mast types

ERGONOMICS & COMFORT

The SCX Series offers a variety of operator conveniences for greater productivity including a low step height, ideal for operators whose daily tasks require repeatedly getting on and off the truck throughout the shift. The operator compartment's side stance design provides comfortable forward or reverse driving. A gently sloped floorboard floats on vibration isolators, to effectively dampen the effects of riding over dock plates or floor joints. An anti-fatigue cushioned floor mat provides added comfort.

The SCX includes a dual-pedal system—with brake release pedal (left) and operator presence pedal (right). Operator comfort is enhanced with thick padding located beneath the operator's arm, back/hips. A cushion for knees is optional.

Standard security features include: return-to-neutral and mast-lock (automatically locking mast lift and tilt) when the operator presence pedal is released, turn control (automatic restriction of travel speed and acceleration during turning), and controlled rollback (reducing and stopping truck movement down a gradient). Communications visible through the LCD meter panel include truck's travel speed, battery capacity, hour meter, time, calendar, and selected power setting.

Exclusive, ergonomic multi-function control handle offers simultaneous control of drive, lift/lower, horn and auxiliary hydraulic functions. Tiller controlled, AC powered, on-demand hydraulic power steering system reduces operator effort for easier maneuvering. A load sensing valve prioritizes hydraulic fluid to truck's steering system when needed. Low height brake pedal improves the ease of operation.

EFFICIENCY & CONTROL

Dual front wheel drive provides excellent traction and braking power. Rugged dual AC drive motors offer more power and quicker response. The SCX Series' individually controlled, AC powered, drive motors mean power is transferred to each motor independently, depending on turn angle input. For tighter turns, the inner wheel counter-rotates allowing greater maneuverability.

The SCX Series may be programmed with Personal Identification Number (PIN) codes to restrict unauthorized truck usage for greater fleet control. Each of the five PINs provide access to a customized operating profile.

The SCX includes three factory-programmed performance settings (Economy, Power, High) which can be modified to fit driver preferences, operating restrictions and/or load handling conditions. Economy mode offers extended run time. Power mode offers mid-range settings. High power mode (standard) is intended for faster acceleration and travel, among other adjustable settings. Use the Manual mode to personalize performance settings. All setting modifications must be made by a trained service technician.

LOWER OPERATING COSTS

The SCX Series features a 100% AC-powered motor and controller system, incorporating a single contactor for reduced maintenance. Truck includes AC pump motor to power its lift and steering system, so a separate steering motor is not required. Motor and controller system design greatly reduces or eliminates many serviceable parts (commutators, contactors and brushes), along with related inspection and replacement expenses. Its AC TECH controller includes a built-in-test-equipment module with self-diagnostics and error code history logged by hour meter reading. Multi-function LCD panel includes on-board diagnostics with all troubleshooting completed through the instrument panel, for reduced service time. No additional handset tool is required.

Four-piece overhead guard simplifies replacement of individual components if necessary, saving time and money. Modular design of the powertrain speeds and simplifies maintenance. The gearbox and motor can be removed, serviced and replaced as a single unit - all without removing the mast.

EFFICIENT PERFORMANCE & GREATER UPTIME

The SCX Series' 100% AC motor and controller system features MOS-FET power inverters for DC to three phase AC power conversion. Thermal sensors help protect both motors and controller against overheating. Warning indicator will advise operator if overheating has occurred, followed by reduced travel and lift operations. Data is automatically locked into truck's service history to assist the technician.

Our AC TECH controller provides lower battery consumption and optimum operating efficiencies through regenerative braking, and on-demand power steering. Advanced regenerative braking technologies help reclaim energy using four efficient operations (switch-back/plugging, operator presence, neutral braking, and brake pedal), contributing to lower power consumption and longer operating hours. Regeneration also results in reduced heat generation and component wear, for long-term savings.

Adjustable auto-power off feature cuts power to the truck's electrical system if unit sits idle for a programmed period of time.

RUGGED & DURABLE

Flat face mast design features rolled steel channels, large cross sections, and thick inner rails for greater capacity retention. Side thrust rollers on the fork carriage are easily accessed for simple carriage adjustment.

The spring applied/electronic released disc brakes are mounted directly to the drive motors, with no brake cylinders or hydraulic brake fluid.

TOTAL **UNICARRIERS**
WAREHOUSE **FORKLIFT**
www.totalwarehouse.com UniCarriersAmericas.com
833-868-2500